

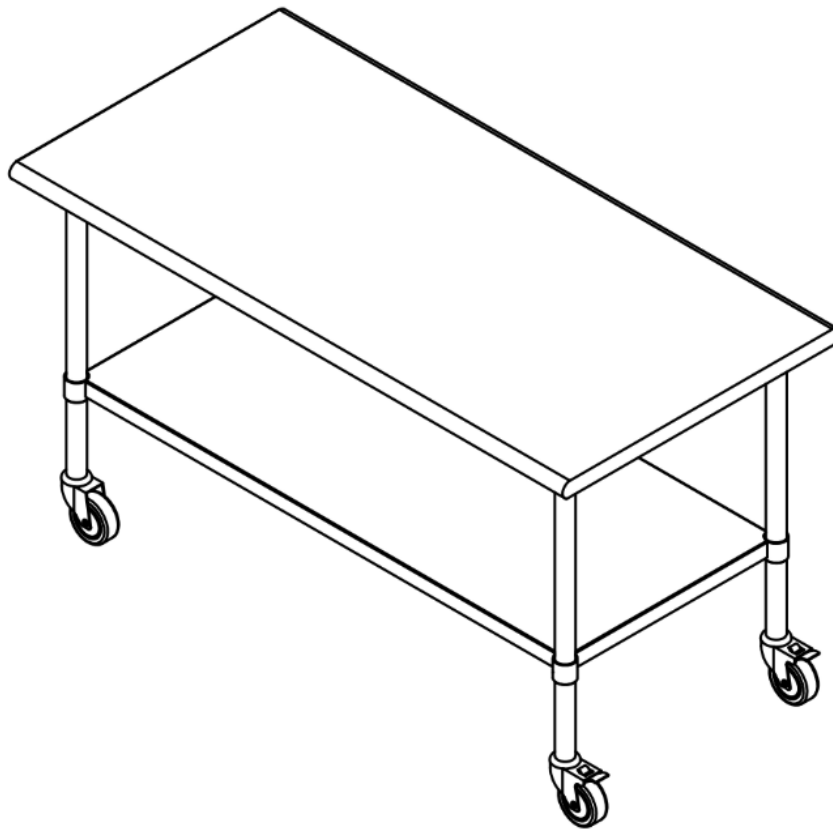

INSTALLATION MANUAL

Stainless Steel Commercial Work Table with Casters

WORK TABLE



Please read these installation instructions carefully to ensure the appliance is installed correctly and operates safely.

For any service related issues, please contact us:

☎ 718-576-6342 ✉ support@koolmore.com

Stay informed with the latest information for your KoolMore Appliance.

Scan the QR code below to access the most recent Installation Manual on our website, which is constantly being updated and improved.

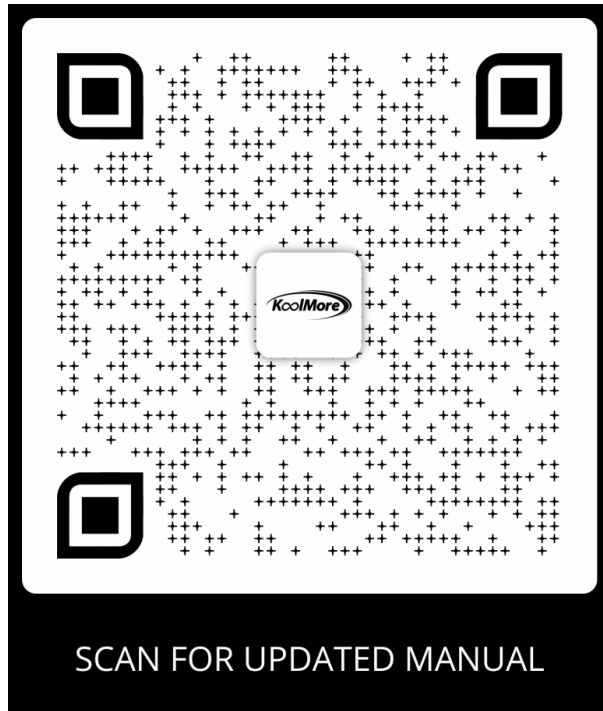

If you need any assistance or have questions, our customer support team is here to help.

Phone- 718-576-6342 Email- support@koolmore.com

Please write down the model number and serial number below for future reference. Both numbers are located on the rating label on the back of your unit or inside of the unit and are needed to obtain warranty service. You may also want to staple your receipt to this manual as it is your proof of purchase and may also be needed for service under warranty.

Model Number: _____
Serial Number: _____
Date of Purchase: _____

To better serve you, please do the following before contacting customer service:

If you received a damaged product, immediately contact the retailer or dealer that sold you the product.

Read and follow this Installation Manual carefully to help you install, use, and maintain your unit.





Refer to the Troubleshooting section of this manual as it will help you diagnose and solve many common issues.

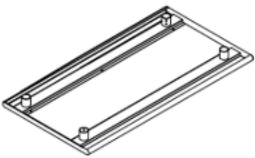
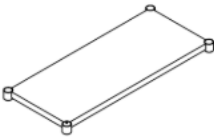

Contents

Parts 4

Installation 5

Parts

Main Parts			
No.	Pattern	Part Name	QTY
1		Top Shelf	1
2		Undershelf	1
3		Leg	4
4		Casters Without Brake	2
5		Casters With Brake	2

Main Parts			
No.	Pattern	Part Name	QTY
1		M8x1x10 Screw	17
2		S4 Screw Wrench	1

Before assembly, unpack all components and verify that all parts are included.

Installation

Step 1

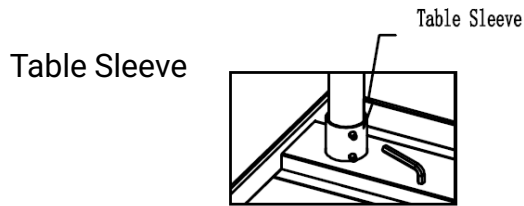

Insert each leg into the table sleeves located at the corners of the tabletop. Ensure each leg is fully seated and aligned vertically. Secure each leg using two set screws, then tighten firmly with the included Allen wrench.

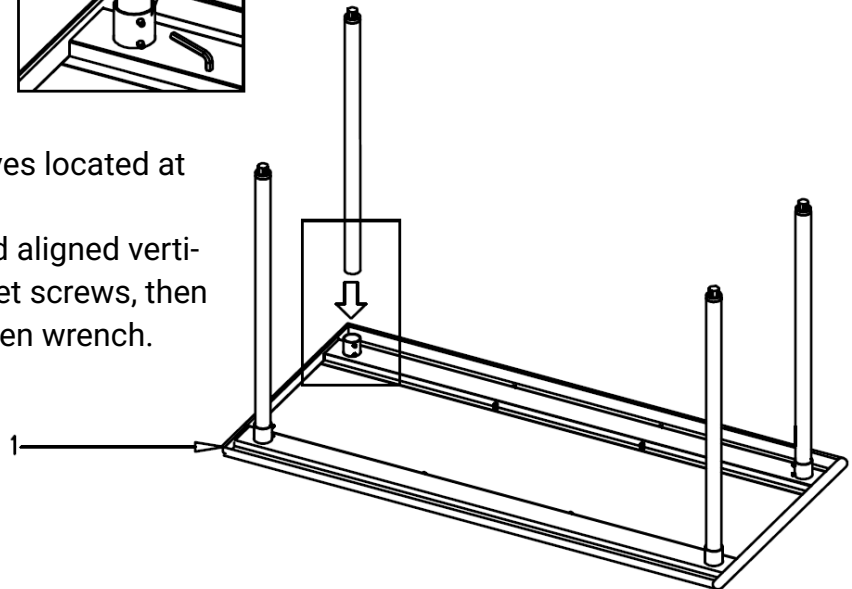

Step 2

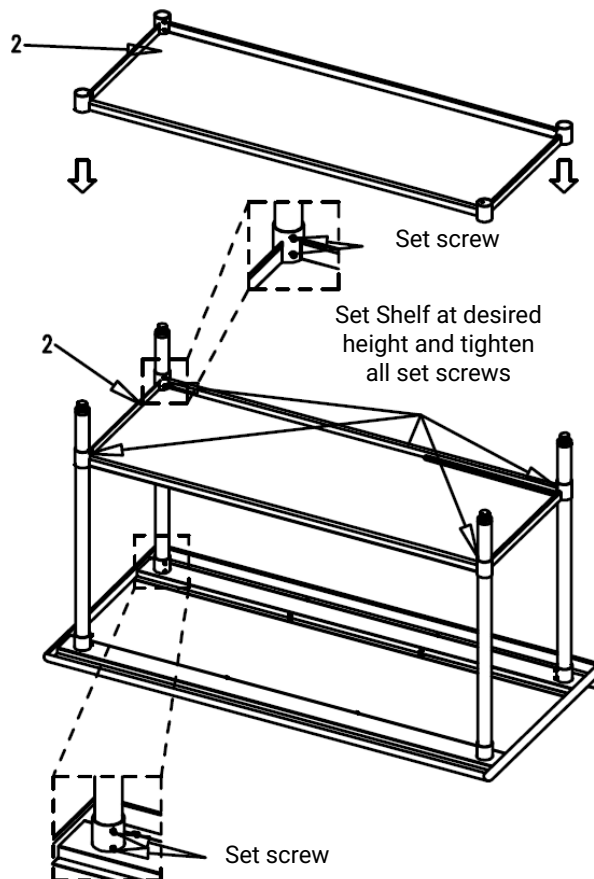

Slide the undershelf onto the legs and position it at the desired height. Once level, tighten all set screws securely using the included Allen wrench.

Step 3

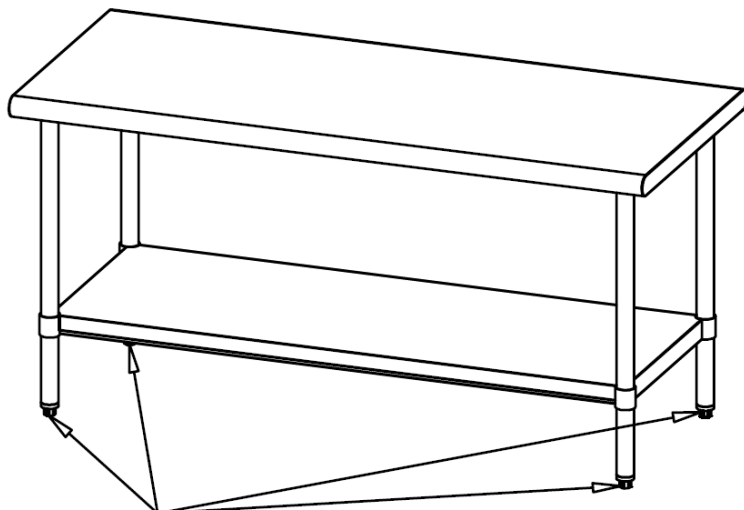

Adjust foot glides if necessary

Place the equipment stand upright.
Adjust the foot glides as needed to level the stand on uneven surfaces.

Step 4

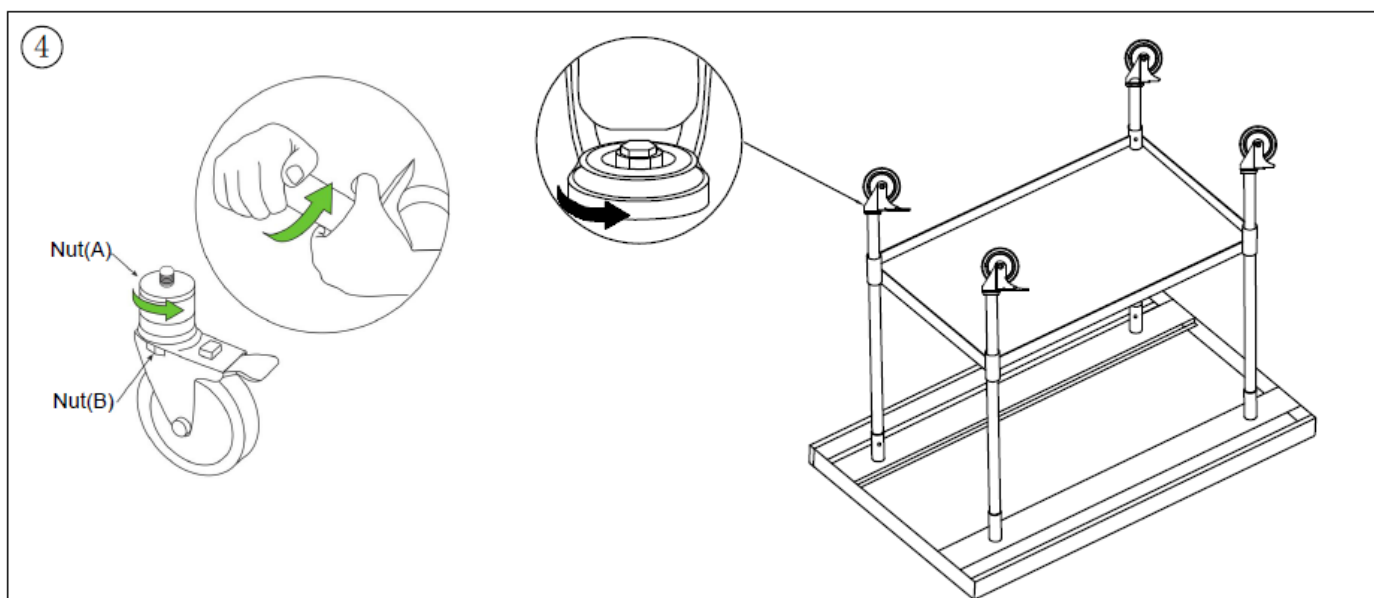

Insert the castor into the leg, if the rubber part is too large for the socket, please loosen the top nut (A) by moving it counter clockwise. Once the stem successfully inserted into the leg, please use a wrench to tighten nut (B) by moving it clockwise until the castor is firmly secured inside the leg.

NOTE: Mobile equipment stands should be secured or restrained when required by local codes. Ensure all set screws are fully tightened before placing equipment on the table.



WARRANTY

LIMITED WARRANTY

KoolMore Supply Inc. extends a limited warranty to the original purchaser, guaranteeing that this KoolMore product is free from manufacturing defects in material or workmanship for one year from the date of purchase.

Should you discover any such defect within the warranty period, KoolMore Supply Inc. reserves the right to repair or replace the product without charge, or to cover the cost of replacement parts and repair labor needed to correct defects present at the time of purchase or resulting from regular usage, when the appliance has been installed, operated, and maintained as per the instructions provided.

At its sole discretion, KoolMore Supply Inc. may decide to replace the product. In such an event, your replacement appliance will carry the warranty for the remaining term of the original unit's warranty period.

This warranty is valid exclusively to the original purchaser of the product and only applicable within the United States. The warranty commences from the date of original consumer purchase. Proof of the original purchase date will be required to obtain service under this warranty.

Under this limited warranty, your sole and exclusive remedy will be product repair, as outlined above. All services must be provided by a KoolMore designated service company.

To claim warranty or request repair service:

Email support@koolmore.com. Please include your name, address, phone number, warranty repair request, and a copy of your proof of purchase receipt. Alternatively, visit koolmore.com and use the Contact Us page. A KoolMore customer service representative will promptly arrange service for your appliance.

We thank you for choosing KoolMore.

WARRANTY EXCLUSIONS

This limited warranty will not cover:

1. Failure of the product to perform during power failures or interruptions, or due to inadequate electrical service.
2. Damage incurred during transportation or handling.
3. Damage caused by accidents, vermin, lightning, winds, fire, floods, or acts of God.
4. Damage resulting from accidents, alterations, misuse, abuse, improper installation, repair, or maintenance. This includes using any external device that alters or converts the voltage or frequency of electricity.
5. Unauthorized product modifications, repairs by unauthorized centers, or use of non-approved replacement parts.
6. Abnormal cleaning and maintenance not aligned with the user's manual.
7. Use of incompatible accessories or components.
8. Any costs associated with repairs or replacements under these excluded circumstances shall be the responsibility of the consumer.

KoolMore