



# SPEC SHEET

## KoolMore 8 cu. ft. Large Capacity Stackable Vented Electric Front Load Dryer in White, 240V,

SKU: FLD-8CWH

### FEATURES

- Front Load Dryer (8 Cu. Ft.)
- 12 Drying Cycles
- Sensor Dry Technology
- Cold Steam Anti-Wrinkle Function
- Efficient Quick-Dry Capabilities
- Stackable with our matching Washer (See model: FLW-5CWH)
- Large capacity Stainless Steel Drum
- See Through Door
- 5 Heating Options



### CLOSE UP IMAGES



# TECHNICAL SPECS

Specification	Detail
Product Dimensions	27 in x 33.7 in x 39.8 in
Product Weight	158 lbs
Material	Stainless Steel Drum
Features	12 drying cycles, cold steam function, quick-dry capabilities, see through door
Color/Finish	White

# Plan View

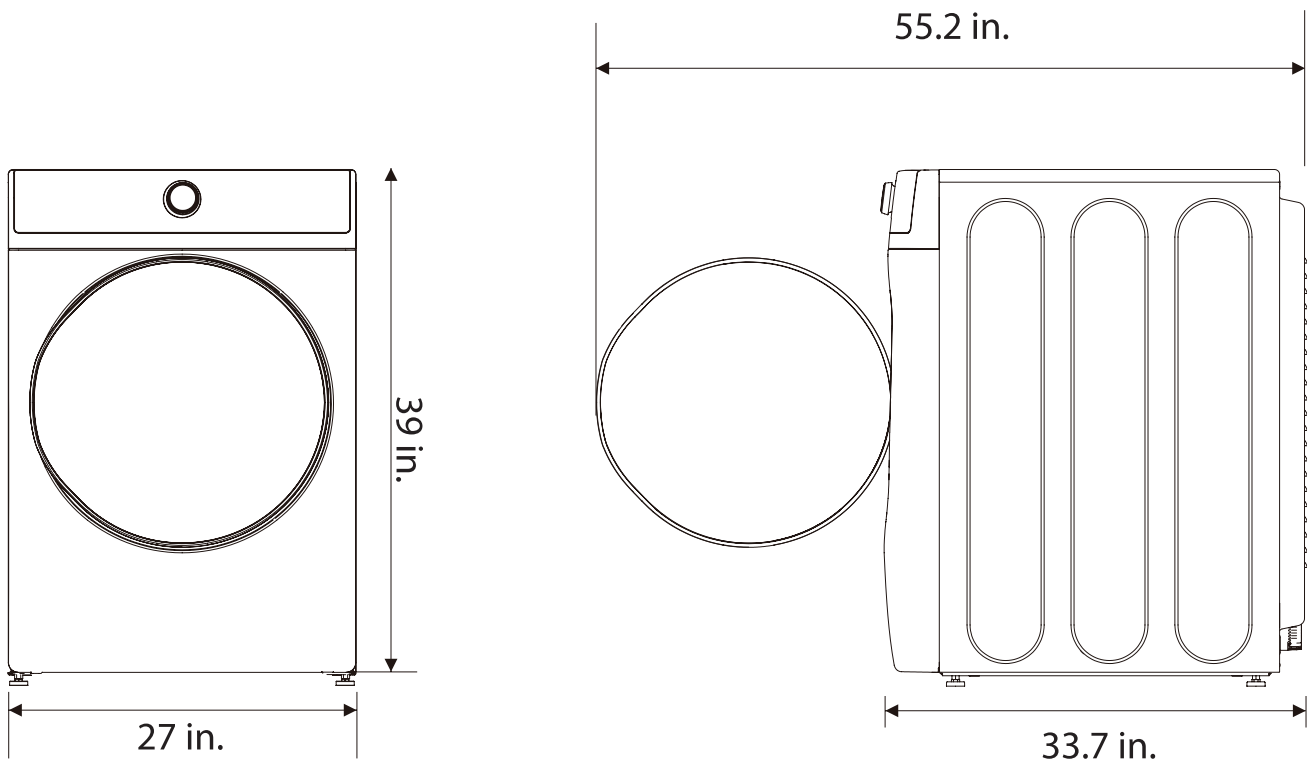

## CERTIFICATIONS



706 Eastern Parkway STE 1G, Brooklyn NY 11213  
718-576-6342  
info@koolmore.com