



SPEC SHEET

72 in. Commercial Three Glass Door Back Bar Cooler Refrigerator, 18 Cu. Ft. Capacity in Stainless-Steel

Model: KM-BC-3GD-SCSS

FEATURES

- **18.3 Cu. Ft. Capacity:** Holds up to 570 standard 12 oz. cans, ideal for high-volume bar and restaurant use.
- **Low-E Glass Doors:** Three tempered swing doors provide clear visibility while improving insulation and energy efficiency.
- **Reliable Cooling System:** Maintains temperatures from 32°F to 50°F and operates effectively in ambient temperatures up to 100°F.
- **Adjustable Heavy-Duty Shelving:** Six metal and PVC shelves, each supporting up to 64 lbs, allow flexible storage for various beverages.
- **Bright LED Interior Lighting:** Top-mounted 6000K–7000K LEDs enhance product visibility and presentation in any lighting environment.
- **Stainless-Steel Construction:** Durable stainless-steel interior and exterior designed for long-term commercial use.
- **Side-Mounted Compressor:** Space-saving design maximizes interior storage while delivering consistent cooling performance.
- **Digital Temperature Controls:** User-friendly thermostat enables precise temperature monitoring and adjustments.
- **Built-In Safety Lock:** Secures inventory during off-hours for added protection.
- **ETL Certified with 1-Year Warranty:** Meets ETL safety standards and includes a 1-year parts and labor manufacturer warranty.



CLOSE UP IMAGES

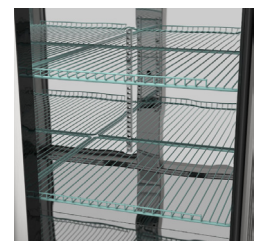
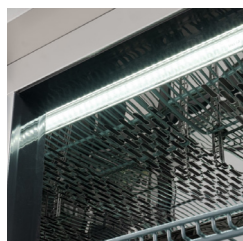

Technical Specs

Dimensions & Weight

Height	34 in.
Width	25 in.
Length	71.9 in.
Weight	231 lbs.
Interior Height	29.17 in.
Interior Width	55.75 in.
Interior Depth	19.96 in.
Depth Excluding Handles	24 in.
Depth Including Handles	25 in.
Depth Less Door	21.98 in.
Depth With Door Open 90 Degrees	39.85 in.
Minimum Back Air Clearance (in.)	4 in.
Minimum Side Air Clearance (in.)	4 in.

Electric & Certifications

Voltage	115
Wattage	290
Hertz	60
Amps	2.6
Phase	1
Plug Type	NEMA 5-15P
Power Cord Length	97.5 in.
Energy Consumption	985.5 KWH/year
Power Cord Included	Yes
Electrical Installation Type	Plug-In
Certifications	ETL Listed for Safety and Sanitation

Capacity

Gross Cubic Feet	18.3
Net Cubic Feet	17.5
Number of Shelves	6
Individual Shelf Capacity	63.8 lbs.

Features & Materials

Temperature Range	32-50 F
Ambient Temperature Range	100 F
Defrost Type	Automatic
Cooling Unit Type	Automatic
Refrigerant Type	R-600a
Horsepower	0.16
Number of Doors	3
Door Handle	Standard
Door Material	Aluminum
Door Handle Color	Silver
Shelves Adjustable	Yes
Door Style	Swing
Reversible Doors	No
Shelf Material Type	Metal and PVC
Shelf Color	Silver
Interior Lights	Yes
Interior Lights Type	LED
Interior Lights Brightness	6000K~7000K
Light Control	Switch
Control Type	Digital
Can Capacity	570
Casters	No
Safety Lock	Yes
Noise	65 dB
Legs Adjustable	Yes, up to 1 in.
Interior Material	Stainless-Steel
Exterior Material	Stainless-Steel
Color	Stainless-Steel
Compressor Location	Side
Glass Type	Tempered

Plan View

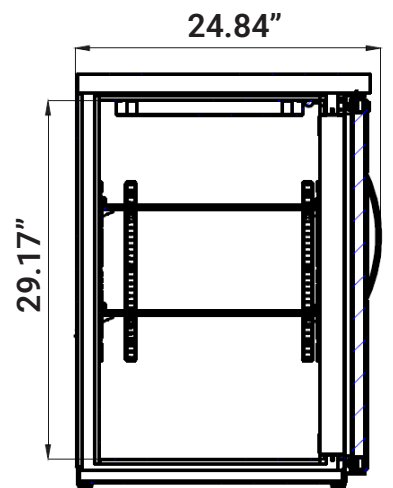
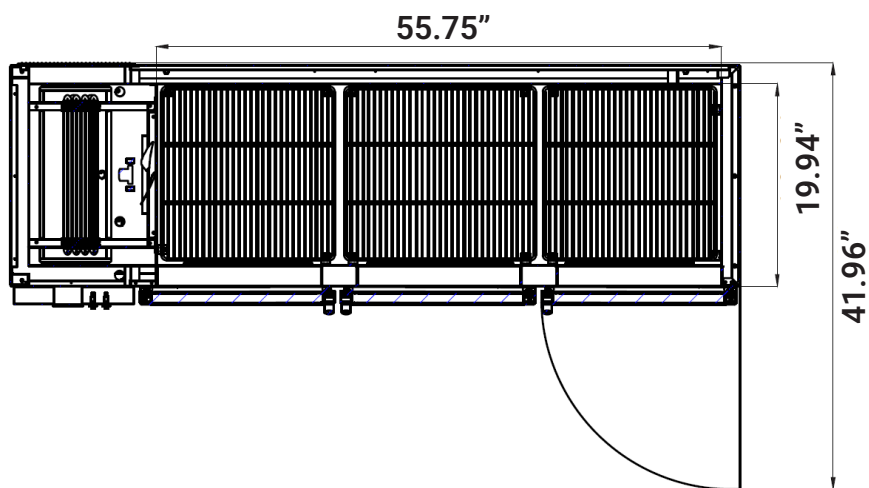
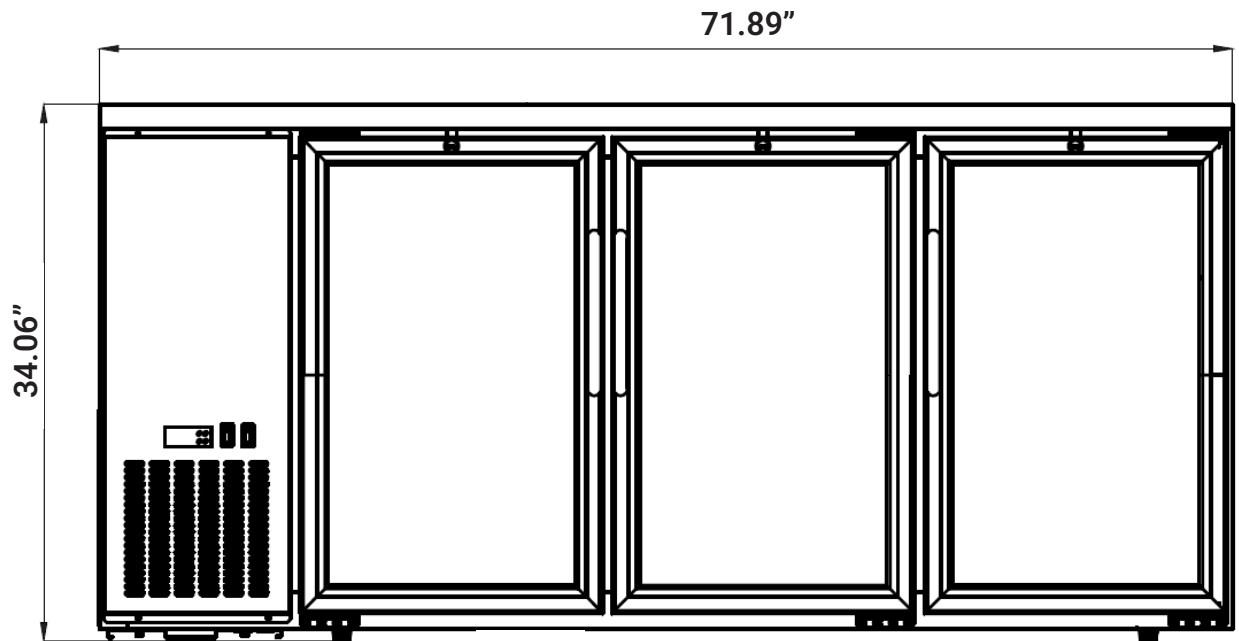

718-576-6342
info@koolmore.com