



USER MANUAL

PANEL READY KITCHEN

KoolMore Panel Ready Compact Refrigerator

Model: KM-BIR5C-PR, KM-BIR15-PR

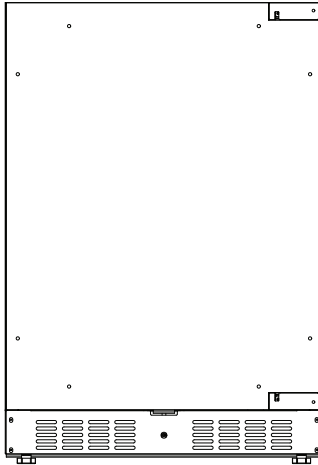

Before using, please read the operating instructions carefully to ensure proper application and achieve satisfactory results.

For any service-related issues, please contact us:



718-576-6342



support@koolmore.com

Stay informed with the latest information for your KoolMore Appliance.

Scan the QR code above to access the most recent user manual on our website, which is constantly being updated and improved.

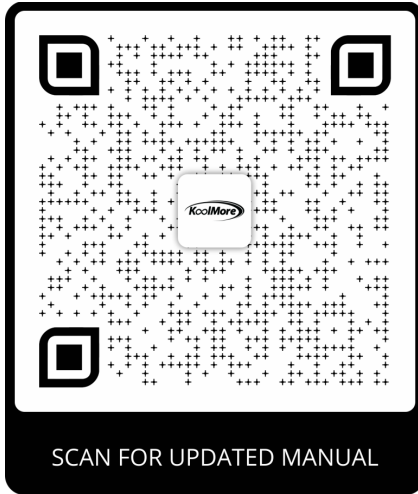

If you need any assistance or have questions, our customer support team is here to help.

P- 718-576-6342 E- Support@koolmore.com

Please write down the model number and serial number below for future reference. Both numbers are located on the rating label on the back of your unit or inside of the unit and are needed to obtain warranty service. You may also want to staple your receipt to this manual as it is the proof of your purchase and may also be needed for service under warranty.

Model Number: _____
Serial Number: _____
Date of Purchase: _____

To better serve you, please do the following before contacting customer service:

If you received a damaged product, immediately contact the retailer or dealer that sold you the product. Read and follow this instruction manual carefully to help you install, use, and maintain your unit. Refer to the Troubleshooting section of this manual as it will help you diagnose and solve many common issues.

INTRODUCTION

INSTALLER: Leave these instructions with the appliance.

CUSTOMER: Read this manual carefully before installing and starting up, and save it for future use. If you pass on the product to another person, hand over this instruction manual along with it. Retain your sales receipt or canceled check. Proof of original purchase date is required for warranty service.

Have the complete model and serial number identification of your appliance ready. These numbers are found on the rating label located inside the door. Record these numbers below for easy access.

Model number _____
Serial number _____
Date of purchase _____

Since we continually improve the quality and performance of our products, we may make changes to the appliance without updating this manual.

ABOUT SAFETY INSTRUCTIONS

Your safety and the safety of others are very important in this manual and on your appliance. Messages we have provided many important safety messages. And have provided on your appliance. Always read and obey all safety messages. The Important Safety Instructions and warnings in this manual are not meant to cover all possible problems and situations that can occur. Use common sense and caution when installing, maintaining or operating this or any other appliance.

Always contact the Customer Service Team about problems or situations that you do not understand.

DANGER

IMPORTANT - Risk of child entrapment!
Child entrapment and suffocation are not problems of the past. Junked or abandoned appliances are still dangerous, even if they will "just sit in the garage a few days".

Before you throw away your old refrigerator or freezer:

- Take off the doors.
- Leave the shelves in place so that children may not easily climb inside.
- Cut the prongs off the power plug and discard them.
- Cut the power cable off and discard it separately from the old appliance.

IMPORTANT: To avoid the possibility of explosion or fire, do not store or use combustible (flammable) or explosive vapors and liquids, such as gasoline inside or in the vicinity of this or any other appliance.

WARNING

IMPORTANT: This appliance is equipped with a three-prong grounding electric plug for protection against possible electric shock hazards. It must be plugged into a dedicated, grounded electrical outlet. If only a two-prong electrical outlet is available, it is the responsibility of the customer to have it replaced with a dedicated, properly grounded three prong electrical outlet.

- DO NOT cut or remove the third (ground) prong from the power cord.
- DO NOT use an adapter.
- DO NOT use a power cord that is frayed or damaged.
- DO NOT use extension cords.
- Keep the power cord away from heated surfaces.

NOTE: Use of an electrical outlet with a ground fault interrupter (GFI) is not recommended.

State of California Proposition 65 Warnings:

WARNING: This product may contain one or more chemicals known to the State of California to cause cancer.
WARNING: This product may contain one or more chemicals known to the State of California to cause birth defects or other reproductive harm.

SAFETY

To reduce the risk of fire, electrical shock or injury when using the appliance, follow basic precautions, including the following:

WARNINGS

- If you receive a damaged product, immediately contact your dealer or builder. Do not install or use a damaged appliance.
- Use this appliance only for its intended purposes. Do not use it to store beverage products, the storage of wine and perishable food, medicine or other medical products if they are not pharmacy appliances. It is not intended for commercial or industrial use for household use only units.
- Make sure that this appliance has been properly installed according to the installation section. Make sure you know the location of the electrical outlet so that you know where and how to disconnect power. Making sure the appliance is properly installed is the responsibility of the customer.
- This appliance is not designed for installation in a recreational vehicle or boat. To prevent personal injury, property damage or damage to the unit, this appliance should only be unpacked and set up by two people according to the installation section.
- Do not install or use outdoors or in wet conditions for indoor use only units.
- Do not place another appliance on top of the appliance.
- Keep packaging materials away from children. Plastic sheets and bags can cause suffocation.
- Connect this appliance to a 115 Vac, 15 Amp, circuit that is controlled by a circuit breaker or fuse. This appliance should have its own separate grounded circuit.
- Do not kink or pinch the power supply cord of the appliance. Never unplug the appliance by pulling on the power cord. Always grip the plug firmly and pull straight out from the electrical outlet.
- To avoid an electric shock hazard, do not operate this appliance with wet hands, or while standing in water or on a wet surface. Disconnect this appliance when not in use.
- Do not install, repair or replace any part of the appliance unless specifically recommended in the literature accompanying it. A qualified service technician should perform all other service.
- Before performing any type of service, disconnect the unit from the electrical outlet. If the power cord is damaged, it must be replaced by the manufacturer, its service agent or similar qualified person in order to avoid a hazard.
- Do not tamper with the controls.
- This appliance is not intended for use by persons (including children) with reduced physical, sensory or mental capabilities, or lack of experience and knowledge, unless they have been given supervision or instruction concerning use of the appliance by a person responsible for their safety. Children should be supervised to ensure that they do not play with the appliance.
- Never allow anyone, including children to sit, stand or climb on any part of the appliance, including the door. Doing so may cause damage, serious injury or death.



Warning: Risk of Fire / Flammable Materials.

- This appliance is CFC and HFC free and contains small quantities of Isobutane (R600a) which is environmentally friendly, but flammable. Great care must be taken during transportation and setting up of the appliance so that no parts of the cooling system are damaged. Leaking coolant can ignite and may damage the eyes. In the event of any damage:
- Avoid open flames and anything which creates a spark.

- Disconnect the power cord from the electrical outlet.
- Air the room in which the appliance is located for several minutes and contact the Customer Service for advice.
- The more coolant there is in an appliance, the larger the room it should be installed in. In the event of a leakage, the appliance is in a small room, there is the danger of combustible gases building up. For every ounce of coolant, at least 325 cubic feet of room space is required. The amount of coolant in the appliance is stated on the data label inside the door. It is hazardous for anyone other than factory authorized service personnel to carry out service or repairs on this appliance.
- Replacing component parts and servicing shall be done by factory authorized service personnel, so as to minimize the risk of possible ignition due to incorrect parts or improper service.
- Take serious care when handling, moving, and using the appliance to avoid either damaging the refrigerant tubing, or increasing the risk of a leak.
- Keep ventilation openings, in the appliance enclosure or in the built-in structure, clear of obstruction. No liability will be accepted for any damage incurred owing to misuse of the appliance or as a result of repairs carried out by unqualified personnel. In this case neither the guarantee nor any other liability claims will apply.
- Do not use mechanical devices or other means to accelerate the defrosting process, other than those recommended by the manufacturer.
- The appliance shall be stored in a room without continuously operating ignition sources (for example: open flames, an operating gas appliance or an operating electric heater).
- Do not pierce or burn. Do not damage the refrigerant circuit. Never use an appliance with a damaged circuit.
- Be aware that refrigerants may not contain an odour.
- Do not use any electrical appliance inside the food storage compartment of the appliance, unless they are of the type recommended by the manufacturer.
- Do not store explosive substances such as aerosol cans with a flammable propellant in this appliance.
- To avoid a hazard due to instability of the appliance, it must be fixed in accordance with the instructions.
- Danger of injury from LED lamp. If the cover is defective: do not look directly into the illumination. The optical lenses from [plastic, possibly with eyes can be injured.
- When positioning the appliance, ensure the supply cord is not trapped or damaged.
- Do not locate multiple portable socket-outlets or portable power supplies at the rear of the appliance.
- Glass breakage. Danger of injury from broken glass. If installed at altitudes above 1500m there is a risk of the glass in the door breaking because of changes in air pressure. Shards of glass can cause severe injury if not handled with care.
- To avoid contamination of food, please respect the following instructions:
- Opening the door for long periods can cause a significant increase of the temperature in the compartments of the appliance.
- Clean regularly surfaces that can come in contact with food and accessible drainage system.
- Clean water tanks if they have not been used for 48 hours, flush the water system connected to a water supply if water has not been drawn for 5 days.
- Store raw meat and fish in suitable containers in the refrigerator, so that it is not in contact with or drip onto other food.
- Two-star frozen-food compartments are suitable for storing pre-frozen food, storing or making ice cream and making ice cubes.
- One, two, and three-star compartments are not suitable for the freezing of fresh food.
- If the refrigerating appliance is left empty for long periods, switch off, defrost, clean, dry, and leave the door open to prevent mould developing within the appliance.

CAUTION

- Keep fingers out of the "pinch point" areas. Clearances between the doors and between the doors and cabinet are necessarily small. Be careful closing doors when children are in the area.
- Do not cover shelves with aluminum foil or any other shelf material which may prevent air circulation.
- In the event of a power outage, minimize opening the door.
- Never clean appliance parts with flammable fluids. These fumes can create a fire hazard or explosion. And do not store or use gasoline or other flammable vapors and liquids in the vicinity of this or any other appliance. The fumes can create a fire hazard or explosion.
- Do not use solvent-based cleaning agents or abrasives on the interior. These cleaners may damage or discolor the interior.
- Please keep the products away from the fire or similar glowing substance before you dispose the appliance.
- Regarding the information pertaining to the use of the appliance, thanks to refer to the below paragraph of the manual.
- Regarding the method for replacing illuminating lamps (if the lamps can be replaced by the user), thanks to refer to the below paragraph of the manual.
- This appliance is intended to be used in household and similar applications such as:
 - staff kitchen areas in shops, offices and other working environments;
 - farm houses and by clients in hotels, motels and other residential type environments;
 - bed and breakfast type environments;
 - catering and similar non-retail applications.
- If you have a lockable appliance, do not keep the key near the appliance or within reach of children.
- It is recommended that a separate circuit serving only your appliance be provided. Use receptacles that cannot be turned off by a switch or pull chain.

Disposal:

Dispose of your appliance packaging properly. Ensure that any plastic wrappings, bags etc. are disposed of safely and kept out of the reach of babies and young children. Danger of suffocation!

Refrigeration equipment must be properly disposed of in a professional and appropriate way, in accordance with the current local regulations and laws which protects the environment this applies to your old appliance and to your new unit once it has reached the end of its service life.

WARNING: Please ensure that old, worn appliances are rendered unusable before disposal by removing the doors, removing the plug, cutting the network cable, and removing or destroying any snap fastenings or bolts. You will thus prevent children from locking themselves in the appliance during play (risk of suffocation) or endangering their lives in any other way. DO NOT dispose of the appliance in landfill as the insulation (Cyclopentane) and refrigerant gas (R600a) contained in these appliances are flammable.

Disposal instructions:

- The appliance must not be disposed of in the dustbin or with normal household rubbish.
- The coolant circuit, particularly the heat exchanger at the back/bottom of the unit, must not be damaged.
- The appliance is not to be handled as normal household waste but is to be taken to a recycling collection point for electrical and electronic goods. By correctly disposing of this product you are contributing to the protection of the environment and to the health of your fellow human beings. Improper disposal endangers health and the environment. Further information about the recycling of the product may be obtained from your town hall, refuse collection department or the store where you purchased the product.

FEATURES

- Installation type varies: can be integrated (built-in) or stand alone (free-standing), contingent upon the specific model.
- Offers a continuous variable electronic temperature regulation, with a digital interface and touchpad for input.
- Temperature settings are adaptable to either Fahrenheit or Celsius units.
- Utilizes a dynamic compressor mechanism that promotes consistent airflow within, achieving a uniform temperature distribution.
- Equipped with a gentle LED light inside, featuring a switch that includes a standard operation mode and an exhibition (Showcase) mode.
- Comes with a door-open and malfunction alert system.
- Features a Shabbos mode, designed to keep the lighting off during certain religious days of observance.
- Boasts a temperature memory feature that resumes operation at the previous temperature setting after a power interruption (such as a power outage or tripping of a circuit breaker).
- Integrates an automatic defrost function that operates through defrost water evaporation.
- The door is reversible to suit various layouts.
- The exterior is finished with a matte steel frame, available in black/white, and is complemented by an interior liner that ensures durability and structural integrity.
- Offers an upgrade option to a stainless steel door with a corresponding handle.
- The door is designed to close by itself.
- Uses eco-friendly refrigerant and insulation foam.
- An optional security feature includes a lock and key system.

Please note, the features and specifications mentioned can be updated or modified without prior notice.

INSTALLATION

Before First Use:

- Remove all packing materials and wash the inside with lukewarm water and mild detergent. Odors from manufacturing will dissipate after the appliance begins cooling.
- After delivery, let the appliance stand upright for at least 24 hours before powering it on to ensure proper oil distribution within the compressor.
- If the door hinge needs to be switched from one side to the other, refer to the manual for instructions on how to reverse the door. Attach the door handle if it's not already in place.

Installation Tips:

WARNING

This appliance must be installed in accordance with all local codes and ordinances.

1. The appliances are designed to be built-in or recessed or free-standing installation.
2. CAUTION: This appliance is designed for storing and cooling wines, beverages and drinks. Do not store perishable food, medicine or other medical products.
3. Place your appliance on a floor/surface that is strong enough to support it when it is fully loaded. To level your unit, adjust the front adjustable legs at the bottom of the unit.
4. For freestanding installation, 5 inches (127mm) of space between the back and sides of the unit are suggested, which allows the proper air circulation to cool the compressor and condenser for energy saving. Even with built-in installation, it is a must to keep ¼" (5mm) space on each side and at the top to ensure proper service access and ventilation. Take care that the air vent at the front of the appliance must never be covered or blocked in any way.
5. Locate the unit away from direct sunlight and sources of heat (stove, heater, radiator, etc.). Direct sunlight may affect the acrylic coating and heat sources may increase electrical consumption. Extreme cold ambient temperatures may also cause the unit not to perform properly.
6. Avoid locating the unit in damp areas.
7. Plug the unit into an exclusive, easily accessible and properly grounded wall outlet. Do not under any circumstances cut or remove the third (ground) prong from the power cord. Any questions concerning power and/or grounding should be directed towards a qualified electrician or an authorized products service centre.
8. The appliance must be installed to all electrical, plumbing, water and drain connections in accordance with state and local codes.
9. IMPORTANT: HIGH HUMID CLIMATE. During periods of high humidity, some condensation may appear on outside surface of glass door. This condensation will disappear when humidity levels drop. For prevention, it is advisable to install the appliance with sufficient ventilation in a dry and/or air-conditioned environment.
10. The appliance has a power switch and/or OFF position for energy saving and safety reasons.

Built-Under Installation:

The appliance should not block the front ventilation. The space between the worktop and the unit should be 31.5 to 35.5 inches for proper airflow. Adjust the front grille as necessary using the screws provided.

BUILT-UNDER INSTRUCTIONS

Make sure your installation does not block the front ventilation grille.

If the unit is fully integrated to be installed for fitting kitchen plinth, make sure that the ventilation gaps in the plinth are at least 118 square inches and remove the ventilation grilles, so that warm air can disperse unhindered. Otherwise, the appliance has to work harder, resulting in an increase in electricity consumption.

NOTE: When pushing the appliance into the niche, make sure that the mains cable does not get trapped.

KM-BIR15-PR

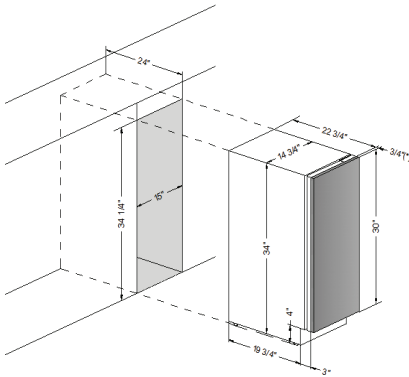

KM-BIR5C-PR

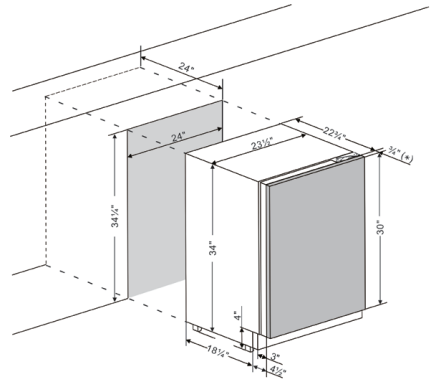

(*) The custom panel and handle are not provided.

ELECTRICAL CONNECTION

Check that the voltage marked on the product corresponds with your supply voltage.

WARNING

Improper use of the grounded plug can result in the risk of electrical shock. If the power cord is damaged, have it replaced by a qualified electrician or an authorized service center.

This appliance should be properly grounded for your safety. The power cord of this appliance is equipped with a three-prong plug which is compatible with standard three-prong wall outlets to minimize the possibility of electrical shock.

Do not under any circumstances cut or remove the third (ground) prong from the power cord supplied. For personal safety, this appliance must be properly grounded.

This appliance requires a standard 115/120 Volt AC ~ 60Hz three-prong grounded electrical outlet. Have the wall outlet and circuit checked by a qualified electrician to make sure the outlet is properly grounded. When a standard 2-prong wall outlet is encountered, it is your responsibility and obligation to have it replaced with a properly grounded 3-prong wall outlet.

To prevent accidental injury, the cord should be secured behind the appliance and not left exposed or dangling.

The appliance should always be plugged into its own individual electrical outlet which has a voltage rating that matches the rating label on the appliance. This provides the best performance and also prevents overloading house wiring circuits that could cause a fire hazard from overheating. Never unplug the appliance by pulling on the power cord. Always grip the plug firmly and pull straight out from the receptacle. Replace or replace immediately all power cords that have become frayed or otherwise damaged. Do not use a cord that shows cracks or abrasion damage along its length or at either end. When moving the appliance, be careful not to damage the power cord.

EXTENSION CORD

Because of potential safety hazards under certain conditions, it is strongly recommended that you do not use an extension cord with this appliance. However, if you must use an extension cord it is absolutely necessary that it be a UL-CUL-listed, 3-wire grounding type appliance extension cord having a grounding type plug and outlet and that the electrical rating of the cord be 115 volts and at least 10 amps.

REVERSING THE DOOR HINGE

It is possible to reverse the door on this appliance, if required.

To do so, follow the steps below:

Note: All parts removed must be saved to do the reinstallation of door.

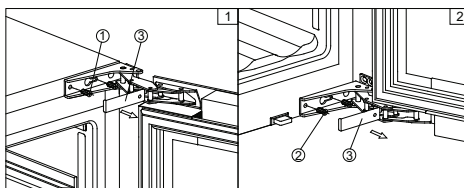

WARNING

Use extreme caution with the articulated hinges. The hinge is self-closing and many pinch points exist prior to built-in installation.

1. Remove the cover cap (3) and then remove the glass door by unscrewing the four screws (1) and (2). Be careful to hold the glass door firmly after removing the screws and place it on a padded surface to avoid the risk of damage.
2. Pop out the cover caps on the left side of cabinet and use them to cover the screw holes on the right hand side.
3. Rotate the glass door 180° and refit the glass door to the opposite side. Then screw and tighten it after the door is leveled.

SECURING THE APPLIANCE

Pop out the two cover caps on the opposite side of hinge and secure the appliance in the niche by tightening the screws through the attachment bracket if the unit is provided with an attachment bracket.

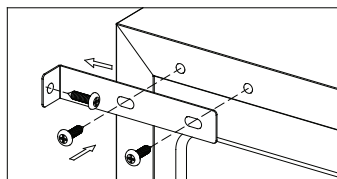

OVERLAY PANEL DOOR DESIGN GUIDE

Model: KM-BIR15-PR, KM-BIR5C-PR

Door panel preparation:

Depending on the model prepare the overlay panel to the dimensions shown below. Then attach the handle to the overlay panel by using the flat head screws and drive the screws flush with the panel if needed.

NOTE:

1. H = Height of door + $3/40"$ [2mm], W = Width of door + $5/32"$ [4mm].
2. Weight of the overlay panel should not exceed 15 Lbs.
3. It is important to ensure that all drilled holes are drilled to the correct depth in order to avoid splits in the wood when hardware is installed.
4. Drill the handle installation holes in the overlay panel according to the handle you are planning to use.

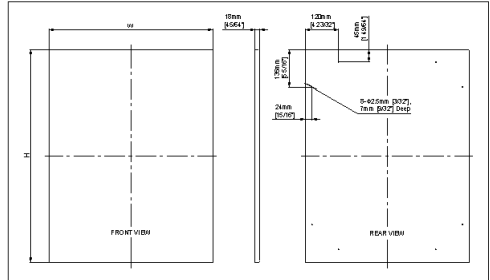

Door panel installation

1. Remove the door gasket (4) completely from door (2). Start in a corner and pull outward. This may take some force. Set gasket down on a flat surface for later installation.
2. Attach the wood overlay panel (1) on the door (2) by using the eight wood screws ST4x30 Type AB Philips (3).
3. Install the wood overlay door on the unit as normal.

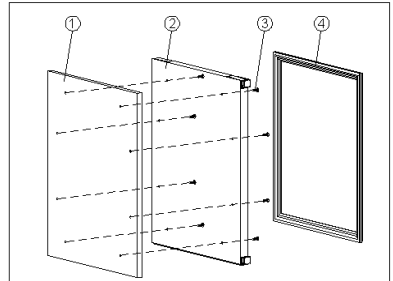

OPERATION

The appliance should be placed in a position where the ambient temperature is between 60°F and 95°F. If the ambient temperature is above or below this range, the performance of the unit may be affected. For example, placing your unit in extreme cold or hot conditions may cause interior temperatures to fluctuate. The range if the set temperature may not be reached.

NOTE:

When you use the appliance for the first time or restart the appliance after having been shut off for a long time, there could be a few degrees variance between the temperature you select, and the one indicated on the LED readout. This is normal and it is due to the length of the activation time. Once the unit is running for a few hours everything will be back to normal.

If the unit is unplugged, has lost power, or is turned off, you must wait 3 to 5 minutes before restarting the unit. If you attempt to restart before this time delay, the unit will not start.

REFRIGERATOR

KM-BIR15-PR , KM-BIR5C-PR

USE AND CONTROL

POWER ①

To turn the appliance off, press and hold the ① key for 5 seconds until temperature display goes out. To turn the appliance on, press and hold the ① key for 1 second until temperature display lights up.

NOTE: Pressing the ① key once can switch off the audible alarm when the alarm is on.

LIGHT ✨

Used to turn the inner light on/off.

To turn the interior light on/off, lightly touch and hold the ✨ key for 5 seconds. The interior light indicator will light up or go out to confirm the selection.

The interior light indicator is the dot at the bottom right of the display.

UP +

Used to increase (warm) the set temperature by 1°F.

DOWN —

Used to decrease (cool) the set temperature by 1°F.

Display

Display the digital temperature and service indicators.

Indicator Light / Multi-key Function

The indicator light is the dot located at the bottom right corner of the display. The indicator light will be flash when a multi-key function is selected. To perform a multi-key function, touch and hold the first key, then touch the rest key for at least 5 seconds and then release all the keys.



°F/°C Selector

Select the temperature display setting in Fahrenheit or Celsius degree. To change the temperature from Fahrenheit to Celsius or from Celsius to Fahrenheit, press and hold the LIGHT key for 5 seconds for models without °F key.

Interior LED Light

The interior light makes it easy to view your items.

* Pressing the LIGHT key toggles between 2 modes of operation for the internal lights: functional (default) mode and showcase mode. If you are in functional (default) mode, the lights will turn on only when the door is open. The interior light will go out approx. 5 seconds after the door is closed. If you are in showcase mode, the lights will be on whether or not the door is open.

The unit is equipped with the LED type lights and they are designed for extremely long life. They are not user serviceable. To change them please contact the service department.

IMPORTANT: Use only the original LED light fittings provided by the manufacturer.

Setting the Temperature Control

- You can set the temperature by touching the UP and DOWN keys. When you press either of the two keys for the first time, the LED readout will show the original temperature set previously. (The temperature preset at the factory is 39°F.
- The temperature will increase 1°F if you press the UP key once, or the temperature will decrease 1°F if you press the DOWN key once. The display flashes while you make the setting. After the temperature has been set, the display shows the current inner temperature.
- The range of set temperatures is from 36°F to 43°F or from 36°F to 54°F or from 36°F to 68°F or from 25°F to 43°F depending on the model.
- To view the set temperature at any time, press the UP or DOWN key; the set temperature will temporarily flash in the display for 5 seconds. Then the display shows the current inner temperature again.

Settings mode

Certain settings on the wine cabinet can only be selected in Settings mode. In Settings mode only the UP and DOWN keys of lower zone are functional.

Touch and hold the UP key for 5 seconds to enter and leave Settings mode. The appliance will leave Settings mode automatically after approximately one minute.

°F/°C Selection

- Lightly touch and hold the UP key for 5 seconds to enter Settings mode.
- Use the UP and DOWN keys to select the temperature display setting in Fahrenheit or Celsius degree.
- Touch and hold the UP key for 5 seconds to confirm the selection.

Display Brightness

- Lightly touch and hold the UP key for 5 seconds to enter Settings mode and then touch the POWER key once.
- Use the UP and DOWN keys to select the brightness of the display when the door is close.
d0: off
d1: dimmest setting (default)
d2: medium setting
d3: brightest setting (same level as when door is opened)
- Touch and hold the UP key for 5 seconds to confirm the selection.

Interior Lighting Brightness

- Lightly touch and hold the UP key for 5 seconds to enter Settings mode and then touch the POWER key twice.
- Use the UP and DOWN keys to select the brightness of the interior lighting when the door is close.
L0: off when the door is close or open
L1: dimmest setting
L2: medium setting
L3: brightest setting (default) (same level as when door is opened)
- Touch and hold the UP key for 5 seconds to confirm the selection.

Fan Mode

- Lightly touch and hold the UP key for 5 seconds to enter Settings mode and then touch the POWER key three (3) times.
- Use the UP and DOWN keys to select the fan mode.
F0: Silent mode - Energy saving mode (default)
F1: DynaClima mode - half time
F2: DynaClima mode - full time
- Touch and hold the UP key for 5 seconds to confirm the selection.

Audible Tones

- Lightly touch and hold the UP key for 5 seconds to enter Settings mode and then touch the POWER key four (4) times.
- Use the UP and DOWN keys to select the audible tones.
S0: keypad tone ON, alarm tone OFF
S1: keypad tone ON, alarm tone ON (default)
S2: keypad tone OFF, alarm tone OFF
S3: keypad tone OFF, alarm tone ON
- Touch and hold the UP key for 5 seconds to confirm the selection.

Interior Light

The interior lighting makes it easy to view items and enhances the display of your collection. Touching and holding the LIGHT key for 5 seconds toggles between 2 modes of operation for the interior lights: functional (default) mode and showcase mode. If you are in functional (default) mode, the lights will turn on only when the door is open. The interior light will go out approx. 5 seconds after the door is closed. If you are in showcase mode, the lights will be on whether or not the door is open.

Dynamic Cooling / Silent Mode

The appliance has two different running modes. In Silent mode once the required temperature is reached, the appliance will run without the fan. In Dynamic Cooling mode the fan cycles on and off to circulate the air even after the required temperature is reached. This ensures consistent humidity and temperature distribution in the unit. Using the dynamic mode increases the level of noise in operation.

Shabbos Mode

Shabbos mode is available for the observance of certain religious holidays. This mode turns off the displays, interior light and audible alarms and prevents them from turning on again. Normal cooling operations will still take place.

To initiate Shabbos mode, press the POWER and LIGHT keys or the POWER and °C/F keys at the same time and hold for at least 5 seconds. The displays and interior lights will go out to confirm the Shabbos mode is ON. Shabbos mode can be canceled by repeating the above process. The Shabbos Mode will automatically turn off after 96 hours.

Temperature Memory Function

In the event of a power interruption (power surge, breaker switch, etc.), the unit can remember the previous temperature settings, and when the power is recovered, the cabinet temperature will return to the same setting temperature as before power off.

DEFROSTING

- Under normal operating conditions, the unit requires no manual defrosting.
- The evaporator behind the rear wall of the unit defrosts automatically. The condensate collects in the drainage channel behind the rear wall of the unit and flows through the drainage hole into the drip tray over/by the compressor where it evaporates.
- However, frost may accumulate on the evaporator if the unit is repeatedly opened in high heat or high humidity locations. If this frost pattern does not clear within 24 hours, your unit will require manual defrosting.

Temperature Alarm and door alarm

- An audible alarm sounds if the storage temperature is not cold enough. The temperature display flashes at the same time.
- The cause of the temperature being too high may be:
 - Warm items were placed inside.
 - Too much warm ambient air flowed in when rearranging and removing contents.
 - Power failure for some time.
 - The appliance is faulty.

- The audible alarm is automatically silenced and the temperature display stops flashing when the temperature is sufficiently cold again.
- If the door has been left open for more than 60 seconds, the alarm will sound. Pressing the POWER key once will switch off the audible alarm.

USING THE FREEZER (IF AVAILABLE)

- The freezer is designed for the long-term storage of frozen food. Storage time is up to three months.
- The storage life of frozen foods varies and the recommended storage time should not be exceeded.
- Pre-packaged commercially frozen food should be stored in accordance with the frozen foods manufacturer's instructions for a three-star frozen food storage compartment or home freezer.
- Place frozen food into the freezer as quickly as possible after purchase. If there are instructions on the packet, carefully follow these instructions regarding storage times.

Eco Demo mode

Eco Demo mode can be activated by presenting the appliance at exhibitions or in salesrooms. In Eco Demo mode, the compressor and all fan motors are switched OFF. Also it is perfect as a cleaning mode. The refrigeration switches off while the lights stay on.

By pressing and holding the "UP" & "DOWN" and "LIGHT" or "°F/°C Selector" at the same time for at least 5 seconds, the indicator light will flash five times to confirm the input and the unit will operate in Eco Demo mode. Eco Demo mode can be canceled by repeating the above process.

Operating Noises

The unit is cooled by a compressor (refrigeration aggregate). The compressor pumps coolant through the cooling system, producing operating noise. Even when the compressor cuts out, noises caused by changes in temperature and pressure are unavoidable. Operating noise will be most audible immediately after the compressor cuts in. It becomes quieter as the operating period continues.

The following noises are normal and occur from time to time:

- Gurgling sound, caused by the refrigerant flowing through the appliance's coils,
- Humming noise made by the motor compressor. This noise can get louder for brief periods when the motor is switching on.
- Crackling/popping sounds, resulting from the materials contraction and expansion due to temperature variations,
- Fan operating sound, to circulate the air within the wine cabinet.

Unusual noise is normally the result of improper installation. Under no circumstances must tubing come into contact with a wall, other furniture or with other tubing.

Where the unit is installed in an open-plan kitchen or in partition walls, the level of operating noise will be heard more acutely. However, this is due to the surrounding architecture and not to the unit.

An individual's perception of noise is directly linked to the environment in which the unit is located, as well as the specific type of model. Our appliances are in line with international standards for such appliances and in line with the latest technical developments. But please remember that the noise of the compressor and the coolant circulating in the system is unavoidable.

MAINTENANCE

WARNING!

- To avoid possible injury due to electric shock, disconnect the power cord or turn off power at the circuit breaker panel or fuse box before cleaning the appliance.
- Clean only the parts of the appliance listed in this manual. Clean them only in the manner specified.
- Do not use a steam cleaner to clean this appliance. Steam could penetrate the electrical components and cause a short circuit.
- Do not allow water or cleaning fluids to penetrate into the electrical components or ventilation grill.
- Use only the types of cleaning solutions specified in this manual. NEVER clean appliance parts with flammable fluids.
- Do not use abrasives such as steel wool, scouring pads, rough sponges or scrub brushes.

REMOVING SHELVES

To prevent damaging the door gasket, make sure to have the door all the way open when pulling the shelves out of the rail compartment.

- For easy access to the stored contents, you can pull the shelf approximately halfway out of the rail compartment. However this unit was designed with a plastic post on each side of the shelf track to prevent shelf contents from falling.
- When removing the shelf from the inner rails, make sure to remove all shelf contents first. Then move the shelf to the position where the notches in the shelf are exactly aligned with the plastic posts and lift the shelf. In order to replace the shelf, repeat this procedure in reverse.

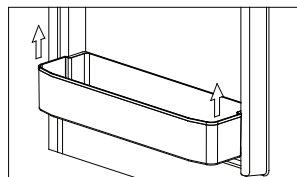
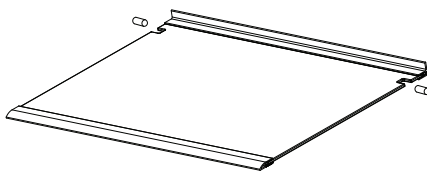

DOOR RACKS

To remove, lift it up and then pull out straight.

DOOR LOCK

If the unit is provided with a lock system, the keys are located inside the plastic bag that contains the Owner's Manual. Insert the key into the lock, push in and turn it counterclockwise to unlock the door. To lock the door do the reverse operation making sure metal pin is engaged completely. Remove the key and place it in a secure place for safekeeping.

CLEANING YOUR APPLIANCE

- Turn off the power, unplug the appliance, and remove all items including shelves.
- Wash the inside surfaces with a warm water and baking soda solution. The solution should be about 2 tablespoons of baking soda to a quart of water.
- Wash the shelves with a mild detergent solution. Wring excess water out of the sponge or cloth when cleaning any area of the controls.
- The sealing gasket around the door must be cleaned regularly to prevent discoloration and prolong service life. Use clean water. After cleaning the sealing gasket, check that it continues to provide a tight seal.
- Wash the outside cabinet with warm water and mild liquid detergent. Rinse well and wipe dry with a clean soft cloth.
- Do not clean the stainless steel with steel wool pads. We suggest using an all-in-one stainless

steel cleaner to clean the stainless steel. Always clean in the direction of the grain.

PREVENTING STAINLESS STEEL RUST

Use non-abrasive tools to clean stainless steel products. Soft cloths and plastic scouring pads will not harm the steel's passive layer.

Clean with polish lines. Some stainless steels have visible polishing lines or "grain". When visible lines are present, always scrub in a motion parallel to the lines. When the grain cannot be seen, polish in a consistent straight pattern and not in a circular motion.

Use alkaline, alkaline chlorinated or non-chloride containing cleaners. While many traditional cleaners are loaded with chlorides, the industry is providing an ever-increasing choice of non-chloride cleaners. If you are not sure of chloride content in the cleaner being used, contact your cleaner supplier. If your present cleaner contains chlorides, ask your supplier for an alternative. Avoid cleaners containing quaternary salt; it also can attack stainless steel and cause pitting and rusting.

Keep food equipment clean. Use alkaline, alkaline chlorinated or non-chloride cleaners at recommended strength. Clean frequently to avoid build-up of hard, stubborn stains. The single most likely cause of damage is chlorides in the water. Remember, adding heat to cleaners that contain chlorides dramatically increases their effect on stainless steel.

If chlorinated cleaners are used, immediately rinse and wipe equipment and supplies dry. The sooner you wipe standing water, especially when it contains cleaning agents, the better. After wiping equipment down, allow it to air dry. Oxygen helps maintain the stainless steel passive film.

POWER FAILURE

In the event of a power interruption, all previous temperature settings are automatically memorized. If power is interrupted (power surge, breaker switch, etc.) and then powered up again, the unit will operate with the last temperature set-point.

Most power failures are corrected within a few hours and should not affect the temperature of your appliance if you minimize the number of times the door is opened. If the power is going to be off for a longer period of time, you need to take the proper steps to protect your contents.

VACATION TIME

Short holidays: Leave the appliance in operation for holidays of less than three weeks.

Long absences: If the appliance will not be used for several months, remove all items, turn off the appliance and unplug. Clean and dry the interior thoroughly. To prevent odor and mold growth, leave the door open slightly, blocking it open if necessary.

MOVING YOUR APPLIANCE

- Unplug the power plug from the electrical outlet.
- Remove the contents from the racks and all moving parts from inside.
- Raise the adjustable legs up to the base to avoid damage.
- Tape the door shut and lock it if with a lock system.
- Transport the appliance only in the upright position. Also protect the outside of the appliance with a blanket or similar item.

ENERGY SAVING TIPS

- Should the unit be left empty for long periods of time, it is suggested that the appliance is unplugged, and after careful cleaning, leave the door ajar to allow air to circulate inside the cabinet in order to avoid possible condensation, mold or odors forming.
- The appliance should be installed in the coolest area of the room, away from heat producing appliances, and out of the direct sunlight.
- Ensure that the unit is adequately ventilated. Never cover air vents. Clean dust and dirt from the condenser at regular intervals.
- Only open the door for as long as necessary and for as short a time as possible.

- Let hot foods cool to room temperature before placing in the unit. Overloading the unit forces the compressor to run longer.
- Be sure to wrap foods properly, and wipe containers dry before placing them in the unit. This cuts down on frost build-up inside the unit.
- Unit shelves and storage bins should not be lined with aluminum foil, wax paper, or paper toweling. Liners interfere with cold air circulation, making the unit less efficient.
- Organize and label food to reduce door openings and extended searches. Remove as many items as needed at one time, and close the door as soon as possible.
- To allow air to circulate, do not overfill the appliance.

TROUBLESHOOTING

PROBLEMS WITH YOUR APPLIANCE

You can solve many common problems easily, saving you the cost of a possible service call. Try the suggestions below to see if you can solve the problem before calling customer service.

PROBLEM	POSSIBLE CAUSE	REMEDY
Appliance does not operate.	<ul style="list-style-type: none"> Appliance is not connected to a power supply. The appliance is turned off. Circuit breaker has tripped or a fuse has blown. 	<ul style="list-style-type: none"> Connect the appliance. Switch on the appliance. Switch on circuit breaker or replace fuse.
Appliance is not cold enough.	<ul style="list-style-type: none"> The temperature is not set correctly. The ambient temperature could require a different temperature setting. The door was opened too often. The door was not closed completely. Door is not hermetically sealed. The condenser is too dirty. The ventilation opening is blocked or too dusty. 	<ul style="list-style-type: none"> Check the set temperature. Set a different temperature. Do not open the door more often than necessary. Close door properly. Check the door seal and clean or replace. Clean the condenser when necessary. Clear the obstructions and clean off the dust.
Appliance turns itself on and off frequently.	<ul style="list-style-type: none"> The room temperature is higher than average. A large amount of bottles has been added to the unit. The door is opened too often. The door is not closed completely. The door gasket does not seal properly. 	<ul style="list-style-type: none"> Put the appliance in a cooler place. Leave the appliance to work for a while until the set temperature has been reached. Do not open the door more often than necessary. Close door properly. Check the door seal and clean or replace.
The light does not work.	<ul style="list-style-type: none"> Appliance is not connected to a power supply. Circuit breaker has tripped or a fuse has blown. The light was switched off on the control panel. 	<ul style="list-style-type: none"> Connect the appliance. Switch on circuit breaker or replace fuse. Switch on the light.
Vibrations.	<ul style="list-style-type: none"> The appliance is not properly level. 	<ul style="list-style-type: none"> Level the appliance with the adjustable feet.
The appliance seems to make too much noise.	The rattling noise may come from the flow of the refrigerant, which is normal. As each cycle ends, you may hear gurgling sounds caused by the flow of refrigerant in your appliance. If temperature fluctuations occur, the contraction and expansion of the inner walls may cause popping and crackling noises.	
	<ul style="list-style-type: none"> The appliance is not properly level. 	<ul style="list-style-type: none"> Level the appliance with the adjustable feet.
The door will not close properly.	<ul style="list-style-type: none"> The appliance is not properly level. The door was reversed and not properly re-installed. The gasket is dirty. The shelves are out of position. 	<ul style="list-style-type: none"> Level the appliance with the adjustable feet. Check the door hinge and reassemble correctly. Clean the door gasket. Check the shelves and refit correctly.

<p>Display “E0”, “E1”, “E2”, “E3”, “E4”, “E5”, “E6” or “E7”.</p>	<ul style="list-style-type: none"> • “E0” indicates a communication error for 3 zone models. • “E1” or “E2” indicates that the air temperature sensor has failed. • “E3” or “E4” indicates that the defrost sensor in the evaporator has failed. • “E5” indicates a defrost heater failure. • “E6” indicates a solenoid valve failure. • “E7” indicates a door switch failure. 	<ul style="list-style-type: none"> • Call for service.
<p>The alarm sounds and the temperature display flashes.</p>	<ul style="list-style-type: none"> • Has the appliance door been open for longer than 60 seconds? If not, then the temperature has risen higher or fallen lower than the temperature that has been set. This could be due to: <ul style="list-style-type: none"> - The appliance door being opened too often. - The ventilation opening being covered or too dusty. - A lengthy interruption to the power supply. - A large amount of bottles has been added to the unit. 	<ul style="list-style-type: none"> • If yes, close the door. <ul style="list-style-type: none"> - Do not open the door more often than necessary. - Clear the obstructions and clean the dust. - Leave the appliance to work for a while until the set temperature has been reached.
<p>The icon “--” is lit up and flashing in the temperature display.</p>	<ul style="list-style-type: none"> • The display temperature is out of the range. 	<ul style="list-style-type: none"> • Only temperatures within the display range 16~99°F can be shown. If the temperature is not within this range, the icon “--” will be displayed instead. That is normal.



WARRANTY

LIMITED WARRANTY

Koolmore Supply, Inc. extends a limited warranty to the original purchaser, guaranteeing that this Koolmore product is free from manufacturing defects in material or workmanship for one year from the date of purchase.

Should you discover any such defect within the warranty period, Koolmore Supply, Inc., reserves the right to repair or replace the product without charge, or to cover the cost of replacement parts and repair labor needed to correct defects present at the time of purchase or resulting from regular usage, when the appliance has been installed, operated, and maintained as per the instructions provided.

At its sole discretion, Koolmore Supply Inc. may decide to replace the product. In such an event, your replacement appliance will carry the warranty for the remaining term of the original unit's warranty period. This warranty is valid exclusively to the original purchaser of the product and only applicable within the United States. The warranty commences from the date of original consumer purchase. Proof of the original purchase date will be required to obtain service under this warranty.

Under this limited warranty, your sole and exclusive remedy will be product repair, as outlined above. All services must be provided by a Koolmore-designated service company.

To claim warranty or request repair service:
Email support@koolmore.com. Please include your name, address, phone number, warranty repair request, and a copy of your proof of purchase receipt. Alternatively, visit koolmore.com and use the contact us page. A Koolmore customer service representative will promptly arrange service for your appliance. We thank you for choosing Koolmore.

WARRANTY EXCLUSIONS

This limited warranty will not cover:

1. Failure of the product to perform during power failures or interruptions, or due to inadequate electrical service.
2. Damage incurred during transportation or handling.
3. Damage caused by accidents, vermin, lightning, winds, fire, floods, or acts of God.
4. Damage resulting from accidents, alterations, misuse, abuse, improper installation, repair, or maintenance.

This includes using any external device that alters or converts the voltage or frequency of electricity.

5. Unauthorized product modifications, repairs by unauthorized centers, or use of non-approved replacement parts.
6. Abnormal cleaning and maintenance not aligned with the user's manual.
7. Use of incompatible accessories or components.
8. Any costs associated with repairs or replacements under these excluded circumstances shall be the responsibility of the consumer.

NOTES

