



SPEC SHEET

20 In. 4.5 Cu. Ft. Glass-Door Beverage Refrigerator with a 120-Can Capacity and Stainless-Steel Trim

Model: KM-BR45SS

FEATURES

- **Larger Capacity:** Designed for higher-volume needs, this 4.5 cu. ft. unit holds up to 120 standard cans, making it ideal for retail displays, offices, breakrooms, or entertainment spaces that require more storage without a full-size footprint.
- **Double-Pane Tempered Glass:** The durable dual-pane glass door provides a clear view of contents while helping maintain consistent internal temperatures and improving overall energy efficiency.
- **Precise Digital Temperature Control (32°F–60°F):** Easily adjust and monitor cooling with a user-friendly digital control panel, allowing you to keep beverages perfectly chilled for a variety of drink types.
- **Consistent Cooling:** A fan-assisted cooling system circulates air evenly throughout the cabinet, eliminating hot spots and ensuring every shelf maintains consistent temperatures.
- **Bright Top-Mounted LED Lighting:** Energy-efficient LED lighting illuminates the interior from above, enhancing visibility and creating an attractive, professional display that draws attention.
- **Quiet Operation at 46 dB:** Engineered for low-noise performance, this unit operates quietly enough for offices, waiting rooms, and residential settings without disruptive sound.
- **Automatic Defrost System for Hassle-Free Maintenance:** Reduces ice buildup and minimizes maintenance, helping the unit operate efficiently over time without manual defrosting.
- **Flexible Installation with Reversible Door & Adjustable Feet:** The reversible swing door and adjustable leveling feet allow for easy placement and stable setup in a variety of spaces.



CLOSE UP IMAGES

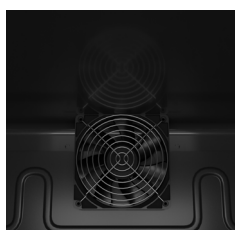

Technical Specs

Dimensions & Weight

Length	20.3 in.
Width	21 in.
Height	31.1 in.
Weight	71 lbs.
Interior Depth	17.7 in.
Interior Width	17.6 in.
Interior Height	27.8 in.
Shelf Depth	14.4 in.
Shelf Width	17.2 in.
Depth Less Door	19.3 in.
Depth With Door Open 90 Degrees	40.2 in.
Height to Top of Door Hinge In.	31.6 in.
Minimum Back Air Clearance In.	4 in. in.
Minimum Side Air Clearance In.	4 in. in.

Electric & Certifications

Voltage	110
Wattage	105
Amps	1.4
Hertz	60
Phase	1
Power Cord Included	Yes
Plug Type	NEMA 5-15P
Power Cord Length	94.49
Energy Consumption KWH Year	347 kWh/year
Certifications	ETL Listed for Safety and Sanitation

Capacity

Gross Cubic Feet	4.6
Net Cubic Feet	4.5
Number of Shelves	4
Individual Shelf Capacity	20 lbs.

Features & Materials

Temperature Range	32-60°F
Ambient Temperature Range	90°F
Defrost Type	Automatic
Cooling Unit Type	Automatic
Refrigerant Type	R600a
Installation Type	Freestanding
Control Type	Digital
Color	Black
Interior Color	Black
Horsepower	0.14
Number of Doors	1
Door Style	Swing
Interior Lights	LED
Interior Lights Color	White
Interior Lights Location	Top
Door Handles Color	Stainless-Steel
Door Material	Glass
Door Handle	Integrated
Can Capacity	120
Reversible Door	Yes
Self Closing Door	No
Noise	46 dB
Indoor/Outdoor	Indoor
Glass Type	Tempered Dual Pane
Shelves Adjustable	No
Shelf Material Type	Glass and Coated Wire
Interior Material	HIPS
Exterior Material	Painted Steel, Glass and Polymer
Legs Adjustable	Yes, .8 in.
Legs Material	ABS
Safety Lock	No
Compressor Location	Bottom

Plan View

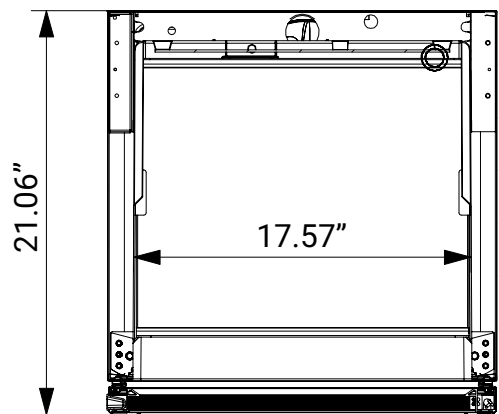
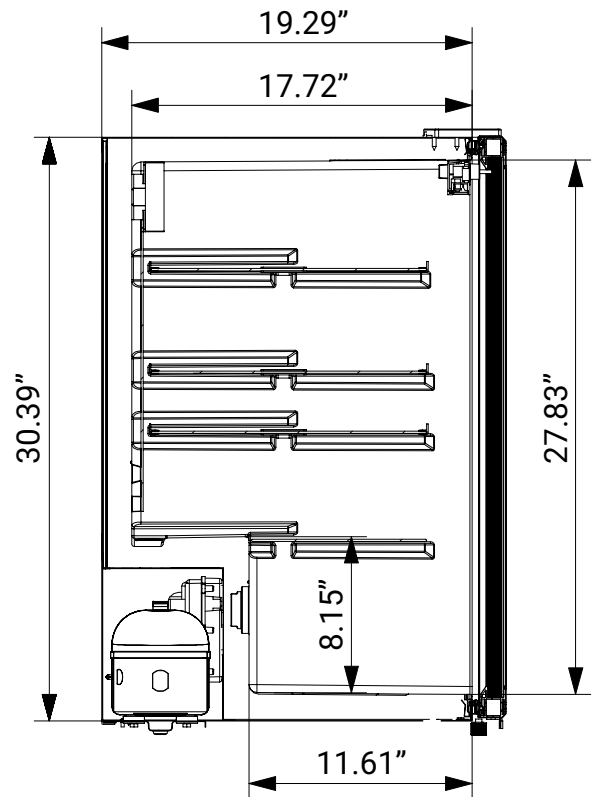
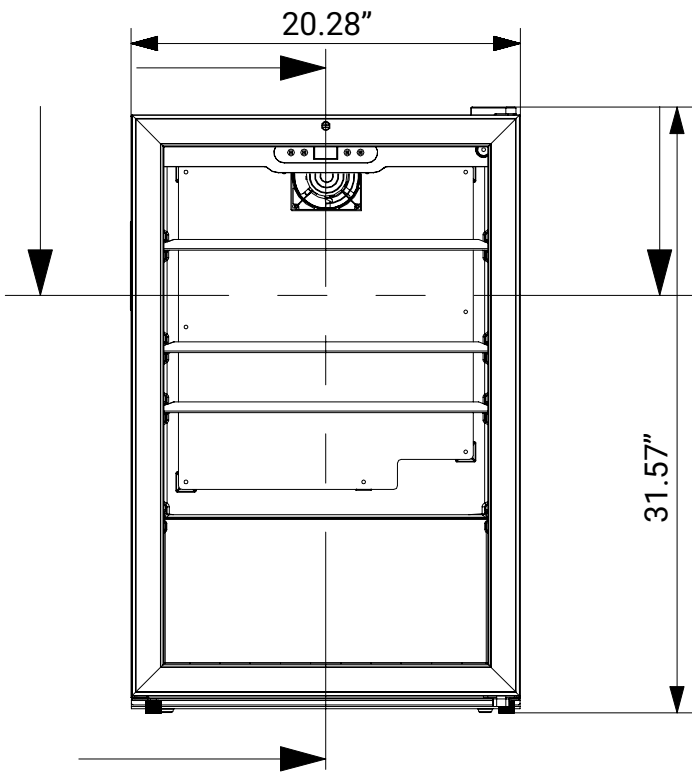

718-576-6342
info@koolmore.com

CERTIFICATIONS

