



SPEC SHEET

KoolMore Commercial 5 Pan Countertop Blast Chiller 30 lbs Rapid Chill / 26.5 lbs Rapid Freeze

Model: **KM-CBLC-5**

FEATURES

- Rapid Chilling: Cools 30.9 lbs. from 194°F to 37°F in 90 minutes, avoiding spoilage range. Stores at 37°F for up to 5 days.
- Quick-Freezing: Freezes 26.5 lbs. from 194°F to 0°F in 238 minutes. Prevents ice crystals, stores cooked food for 2 months, raw for 12 months.
- Auto Preservation: Transitions to refrigeration mode after chilling/freezing (short-term storage only).
- Food Probe System: Monitors food temperature with a heated probe for effortless removal.
- 1 HP Compressor: Delivers fast, uniform cooling for demanding commercial kitchens.
- Stainless Steel Build: 304-grade interior for hygiene; 201-grade exterior for durability.
- Digital Controls: Set and monitor temperatures as low as -22°F with precision.
- 5-Pan Capacity: Holds up to 55 lbs. with space for 5 full-size pans.
- Compact and Quiet: Countertop design, operates at 70 dB for a quieter kitchen.
- Easy Maintenance: Features automatic defrost and removable dust gauze for quick cleaning.
- Certified & Warranty: ETL, HACCP compliant with a 1-year parts and labor warranty.



CLOSE UP IMAGES



TECHNICAL SPECS

Dimensions

Length	29.5
Width	30
Height	35.25
Weight Lbs	153
Interior Depth	16.14
Interior Width	25.28
Interior Height	14.76
Depth Excluding Handles	30.04
Depth Including Handles	30.04
Depth Less Door	30
Depth With Door Open 90 Degrees	57.03
Power Cord Length	59
Minimum Back Air Clearance (In)	4 In.
Minimum Side Air Clearance (In)	4 In.

Capacity

Gross Cubic Feet	3.49
Pan Capacity	5 Full Size
Maximum Shelf Capacity	11 lbs.

Features & Materials

Defrost Type	Automatic
Refrigerant Type	R-290
Cooling Unit Type	Automatic
Compressor Location	Bottom
Number Of Doors	1
Door Style	Swing
Number Of Shelves	5
Temperature Range	-22 F
Ambient Temperature Range	64-89.6 F
Control Type	Digital
Color Finish	Brushed Stainless-steel
Color Door Handles	Brushed Stainless-steel
Hinge Location	Right Side
Reversible Door(s)	No
Self-Closing Door	No
Noise	70 db
Interior Material	Stainless-Steel 304
Exterior Material	Stainless-Steel 201
Door Material	Stainless-Steel
Gauge Of Stainless Steel	26
Legs Material	Plastic and Stainless-Steel
Legs Adjustable	Yes

Electric & Certification

Amps	6.4
Hertz	60
Horsepower	1
Phase	1
Plug Type	NEMA 5-15P
Voltage	120
Wattage	660
Certifications	ETL Listed for Safety and Sanitation and HACCP Compliant

Plan View

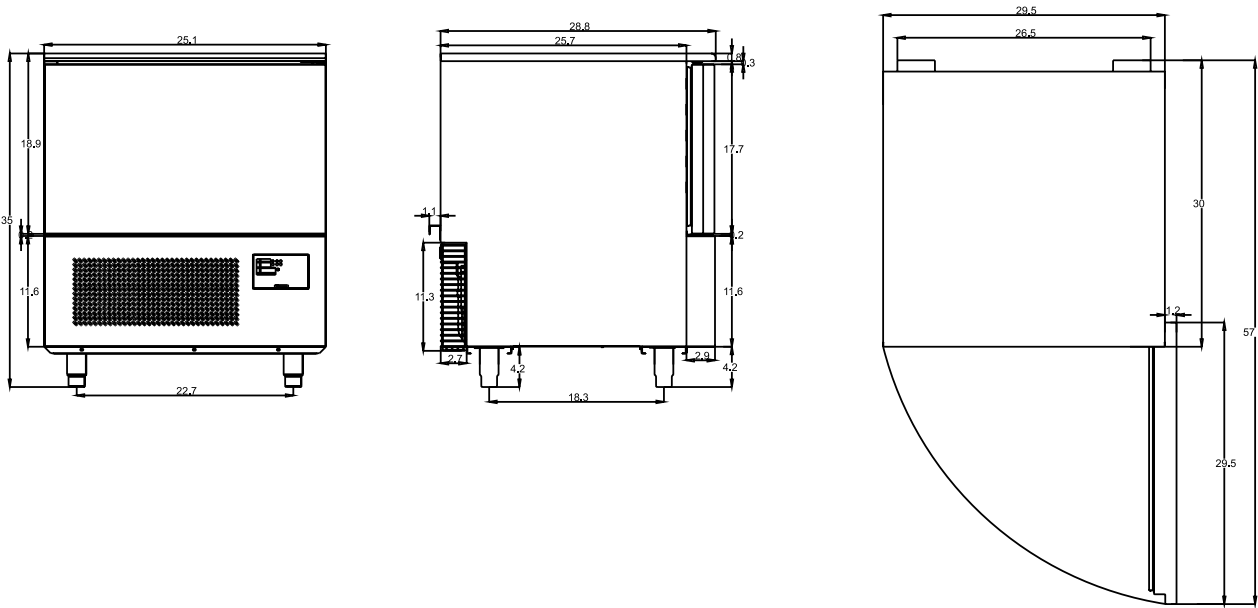

CERTIFICATIONS

Intertek Intertek



706 Eastern Parkway STE 1G, Brooklyn NY 11213
718-576-6342
info@koolmore.com