



SPEC SHEET

24 Cu. Ft. Commercial Beverage Merchandiser with Sliding Glass Doors in Black

Model: KM-CDA-SL24C

FEATURES

- **Large 24 Cu. Ft. Capacity:** Designed to handle busy retail environments, this unit holds up to 400 cans (12 oz.) or 280 bottles (16 oz.), providing ample space to keep beverages fully stocked and visible.
- **Sliding Double Glass Doors for Space Efficiency:** Dual sliding tempered glass doors allow easy customer access while saving space, making it ideal for aisles and high-traffic areas.
- **Bright LED Lighting Throughout the Interior:** Features LED lighting on the top and under each shelf, ensuring products are evenly illuminated for maximum visibility and an attractive display.
- **Precise Digital Temperature Control (32°F–53.6°F):** Easily adjust and monitor temperature using the exterior digital control panel to maintain optimal cooling for a variety of beverages.
- **Ventilated Cooling System for Even Airflow:** Fan-assisted cooling distributes cold air evenly throughout the cabinet, ensuring consistent temperatures across all shelves.
- **Durable Adjustable Shelving with High Load Capacity:** Includes four adjustable painted steel shelves, each supporting up to 44 lbs., allowing flexible organization for different product sizes.
- **Smooth Mobility with Locking Casters:** Equipped with four casters, including two locking wheels, making it easy to move and securely position the unit where needed.



CLOSE UP IMAGES

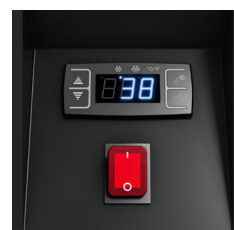

Technical Specs

Dimensions & Weight

Length	51.65 in.
Width	28.14 in.
Height	70 in.
Weight	452 lbs.
Interior Depth	21.3 in.
Interior Width	49.9 in.
Interior Height	46.1 in.
Shelf Depth	14.5 in.
Shelf Width	47 in.
Depth Excluding Handles	27.5 in.
Depth Including Handles	28.14 in.

Electric & Certifications

Voltage	110
Wattage	640
Amps	6.1
Hertz	60
Phase	1
Power Cord Included	Yes
Plug Type	NEMA 5-15P
Power Cord Length	94.49 in.
Energy Consumption KWH Year	2847 kWh/year
Certifications	ETL Listed for Safety and NSF for Sanitation

Capacity

Gross Cubic Feet	24.7
Net Cubic Feet	17.1
Number of Shelves	4
Individual Shelf Capacity	44 lbs.

Features & Materials

Temperature Range	32-53.6°F
Ambient Temperature Range	89.6°F
Defrost Type	Automatic
Cooling Unit Type	Automatic
Refrigerant Type	R290
Installation Type	Freestanding
Control Type	Digital
Color	Black
Interior Color	White
Commercial Residential	Commercial
Horsepower	0.25
Number of Doors	2
Door Style	Sliding
Interior Lights	LED
Interior Lights Color	White
Interior Lights Location	Top and Under Each Shelf
Door Handles Color	Silver
Door Material	Glass
Door Handle	Standard
Can Capacity	400
Reversible Door	No
Self Closing Door	No
Noise	50 dB
Indoor/Outdoor	Indoor
Glass Type	Tempered Dual Pane
Shelves Adjustable	Yes
Shelf Material Type	Painted Steel
Interior Material	Painted steel
Exterior Material	Glass, Paninted Steel and Polymer
Casters	4
Safety Lock	No
Compressor Location	Bottom

Plan View

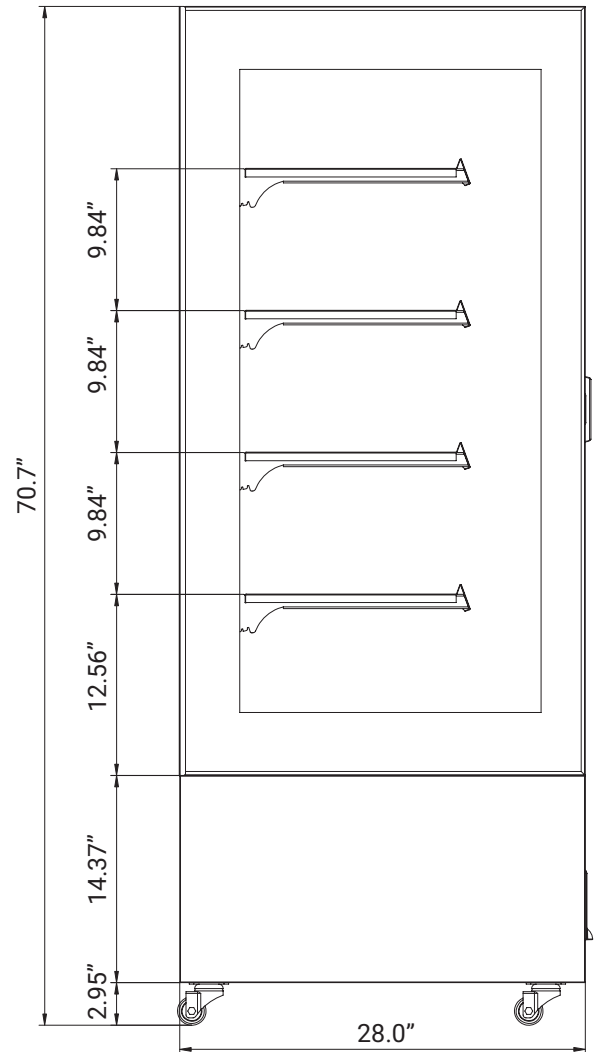
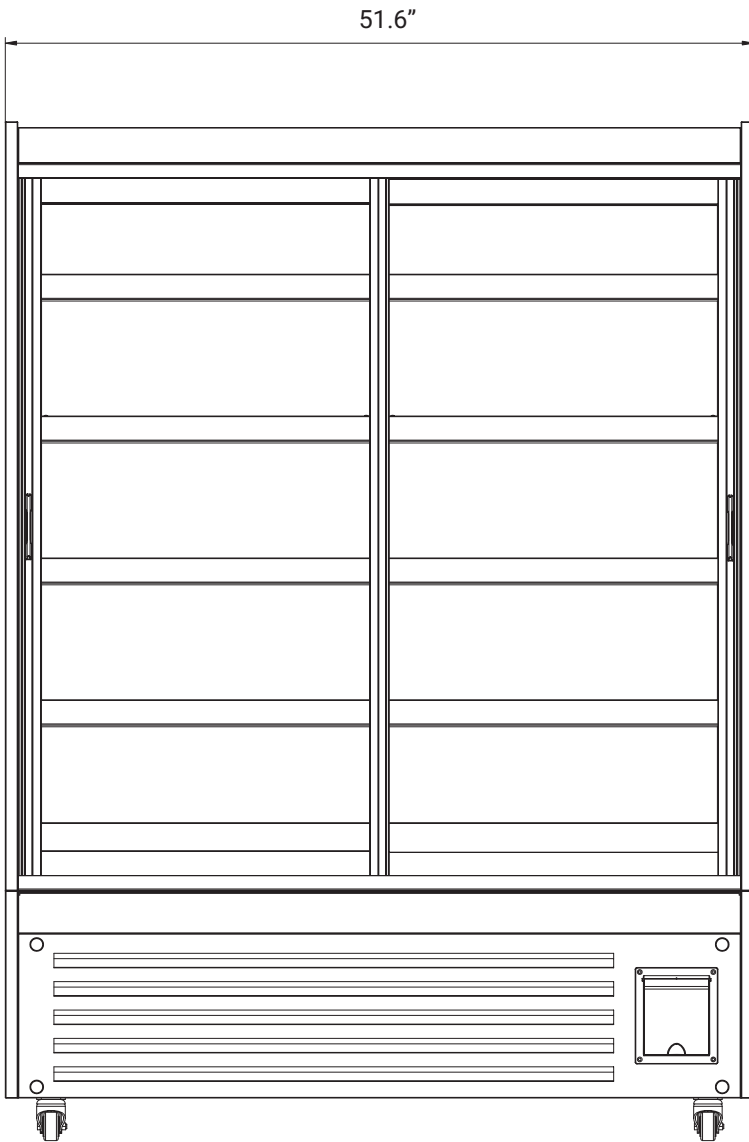

718-576-6342
info@koolmore.com

