



SPEC SHEET

31 In. Countertop Ice Cream Display case with 4 Pans and Glass Sneeze Guard in Stainless-Steel

Model: KM-CGD-8HP

FEATURES

- **Stainless Steel Construction:** Built with durable stainless steel and double-tempered glass, this unit provides long-lasting performance while ensuring your gelato and other frozen treats are safely displayed.
- **Four Pans for Serving Variety:** Comes equipped with four 1/3 GN-sized pans, allowing you to display multiple flavors of gelato, making it easier for customers to choose and for staff to serve.
- **Static Cooling for Optimal Temperature Control:** Featuring a static cooling system that maintains a temperature range of -8-0°F, this freezer is ideal for preserving ice cream without compromising texture or quality.
- **Digital Temperature Control for Convenience:** Easily adjust temperatures with the digital control panel, allowing for precision cooling of gelato or other frozen goods to keep them fresh and ready for service.
- **Flat Glass Display Cover for Visibility and Protection:** The elegant glass display cover not only showcases your ice cream but also protects it from external contaminants, enhancing both hygiene and visual appeal.
- **Compact Countertop Design:** Designed for countertop use, this compact freezer fits seamlessly into small spaces, making it ideal for cafés, ice cream parlors, or food trucks.
- **Energy Efficient:** Operating at just 870 KWH/year, this unit is designed to save on energy costs, making it both environmentally friendly and economical for daily operations.



CLOSE UP IMAGES

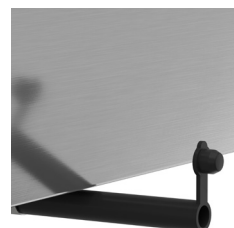

Technical Specs

Dimensions & Weight

Length	31.69 in.
Width	25.6 in.
Height	11.42 in.
Weight	75 lbs.
Interior Depth	26.18 in.
Interior Width	13.98 in.
Interior Height	7.68 in.
Pan Capacity	Four 1/3 GN Pans 12.8 x 6.3 x 3.9 in.
Minimum Back Air Clearance	2 in.
Minimum Side Air Clearance	2 in.

Electric & Certifications

Voltage	110
Wattage	190
Hertz	60
Amps	2.1
Phase	1
Plug Type	NEMA 5-15P
Electrical Installation Type	Plug-in
Power Cord Included	Yes
Power Cord Length	94.5 in.
Energy Consumption	870 KWH/year
Certifications	ETL Listed for Safety and Sanitation

Capacity

Gross Cubic Feet	3.5
Number of Pans	4

Features & Materials

Temperature Range	-8-0°F
Ambient Temperature Range	86°F
Defrost Type	Automatic
Cooling Unit Type	Static
Refrigerant Type	R-290
Horsepower	0.33
Control Type	Digital
Control Location	Exterior
Installation Type	Countertop
Number of Doors	1
Doors Style	Vertical Swing
Doors Material	Glass
Color Door Handles	Black
Reversible Door	No
Commercial Residential	Commercial
Indoor Outdoor	Indoor
Glass Type	Double-Tempered
Interior Material	201 Stainless-Steel
Exterior Material	201 Stainless-Steel, Glass and Plastic
Color Finish	Stainless-Steel and Black
Interior Color	Stainless-Steel
Interior Lights	No
Noise	48 dB
Legs Adjustable	Yes
Number of Feet	4
Hinge Location	Back
Safety Lock	No
Compressor Location	Bottom

Plan View

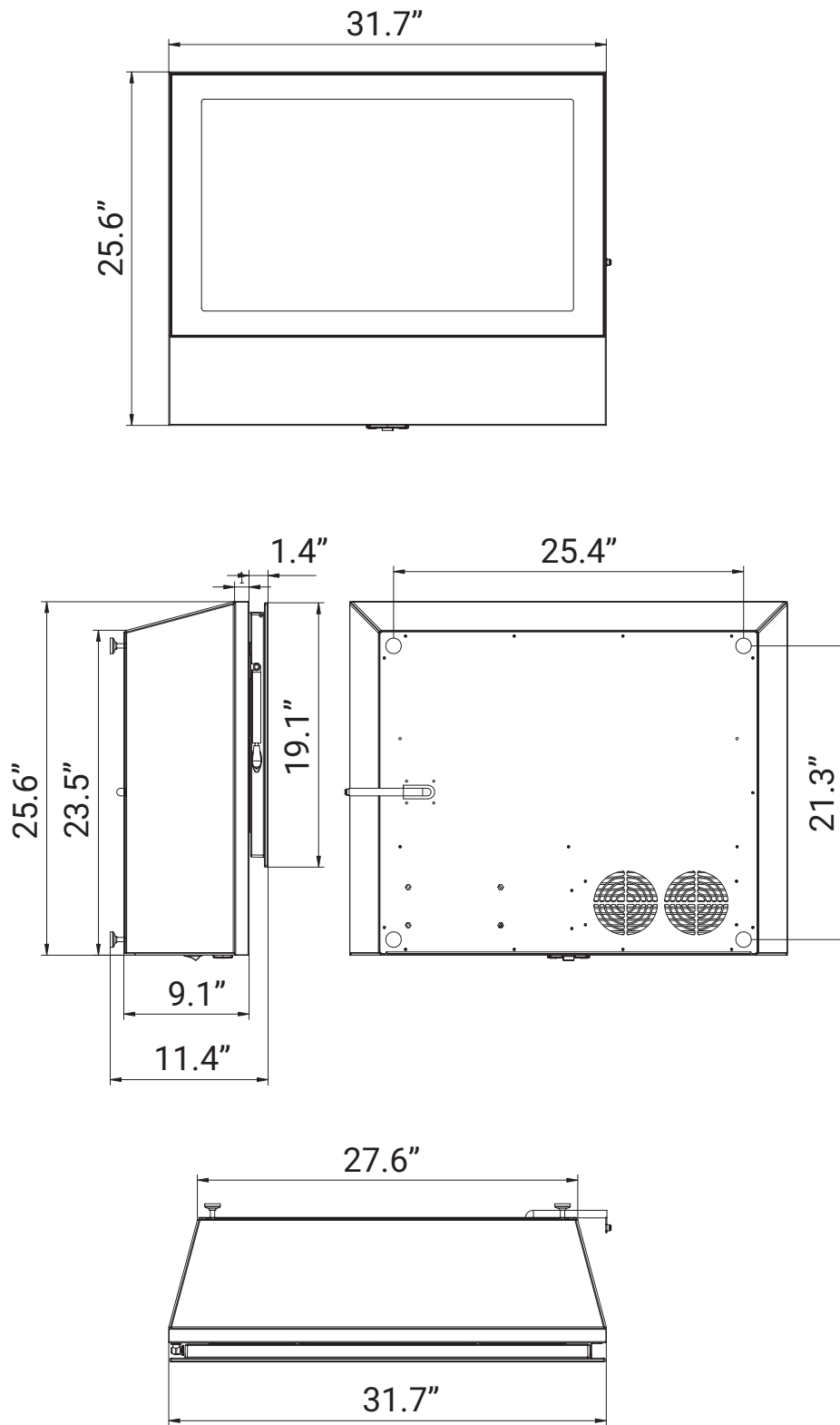

718-576-6342
info@koolmore.com

CERTIFICATIONS

