



SPEC SHEET

39 In. 5-Pan Countertop Ice Cream Display Freezer with Curved Glass Top in Stainless-Steel

Model: KM-CGDR-5P

FEATURES

- **Stainless Steel Construction:** Built with durable stainless steel and double-tempered glass, this unit provides long-lasting performance while ensuring your ice cream and other frozen treats are safely displayed.
- **Five 5L Pans for Serving Variety:** Comes equipped with five 5L-sized pans, allowing you to display multiple flavors of ice cream.
- **Static Cooling for Optimal Temperature Control:** Featuring a static cooling system that maintains a temperature range of -7.6°F to 10.4°F, this freezer is ideal for preserving ice cream without compromising texture or quality.
- **Digital Temperature Control for Convenience:** Easily adjust temperatures with the digital control panel, allowing for precision cooling of ice cream or other frozen goods.
- **Curved Glass Display Cover:** The elegant curved glass display cover not only showcases your ice cream but also protects it from external contaminants, enhancing both hygiene and visual appeal.
- **Compact Countertop Design:** Designed for countertop use, this compact freezer fits seamlessly into small spaces, making it ideal for cafés, ice cream parlors, or food trucks.
- **Soft-Closing Cover:** The soft-closing feature ensures smooth operation, preventing slams that could damage the unit or the frozen contents, ensuring a longer lifespan for both.
- **Energy Efficient:** Operating at just 1080 KWH/year, this unit is designed to save on energy costs, making it both environmentally friendly and economical for daily operations.



CLOSE UP IMAGES

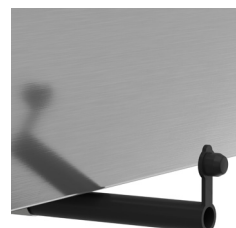
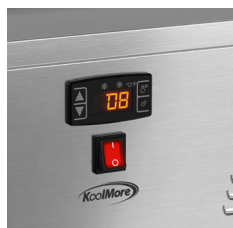
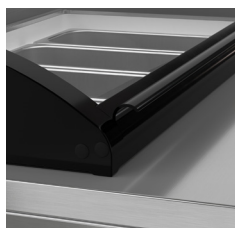

Technical Specs

Dimensions & Weight

Length	38.38 in.
Width	86 in.
Height	14.6 in.
Weight	76.27 lbs.
Interior Depth	13.98 in.
Interior Width	32.95 in.
Interior Height	7.68 in.
Pan Capacity	5L Ice-Cream Pans 14.17"x 6.5" x 4.72"
Maximum Depth of Pans	4.7 in.
Minimum Back Air Clearance In.	4 in.
Minimum Side Air Clearance In.	4 in.

Electric & Certifications

Voltage	120
Wattage	150
Hertz	60
Amps	2.1
Phase	1
Plug Type	NEMA 5-15P
Power Cord Included	Yes
Power Cord Length	94.5 in.
Energy Consumption KWH Year	1080 KWH/Year
Certifications	ETL Listed for Safety and Sanitation

Capacity

Gross Cubic Feet	2.93
Number of Pans	5

Features & Materials

Temperature Range	-7.6-10.4°F
Ambient Temperature Range	60-90°F
Defrost Type	Automatic
Cooling Unit Type	Static
Refrigerant Type	R-290
Horsepower	0.25
Control Type	Digital
Installation Type	Countertop
Number of Doors	1
Doors Style	Vertical Swing
Glass Type	Double-tempered
Interior Material	Plastic Liner
Exterior Material	Stainless-Steel and Glass
Color Finish	Stainless-Steel and Black
Interior Color	White
Interior Lights	No
Legs Adjustable	Yes
Feet Material	Plastic
Casters	No
Safety Lock	No
Compressor Location	Bottom of Front Side

Plan View

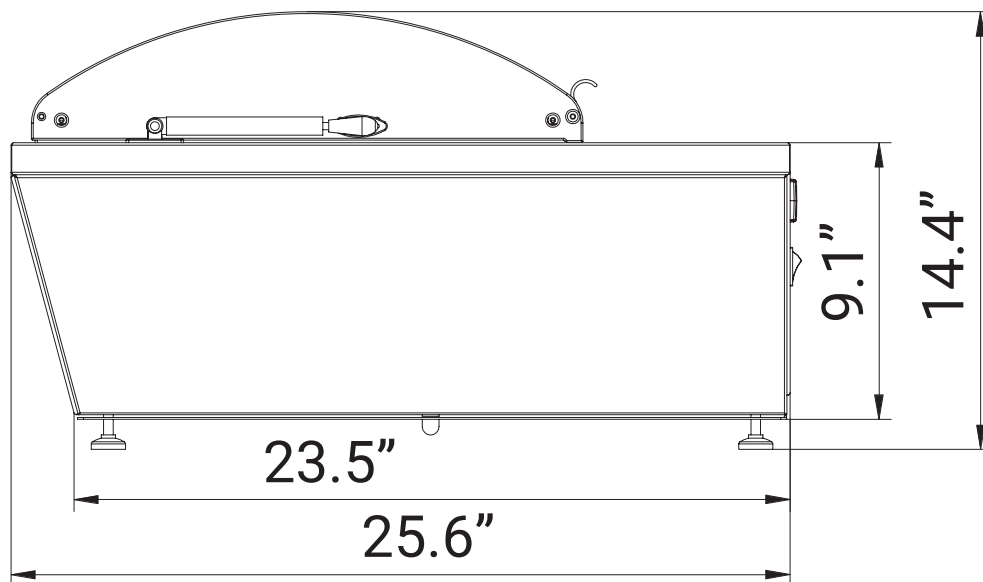
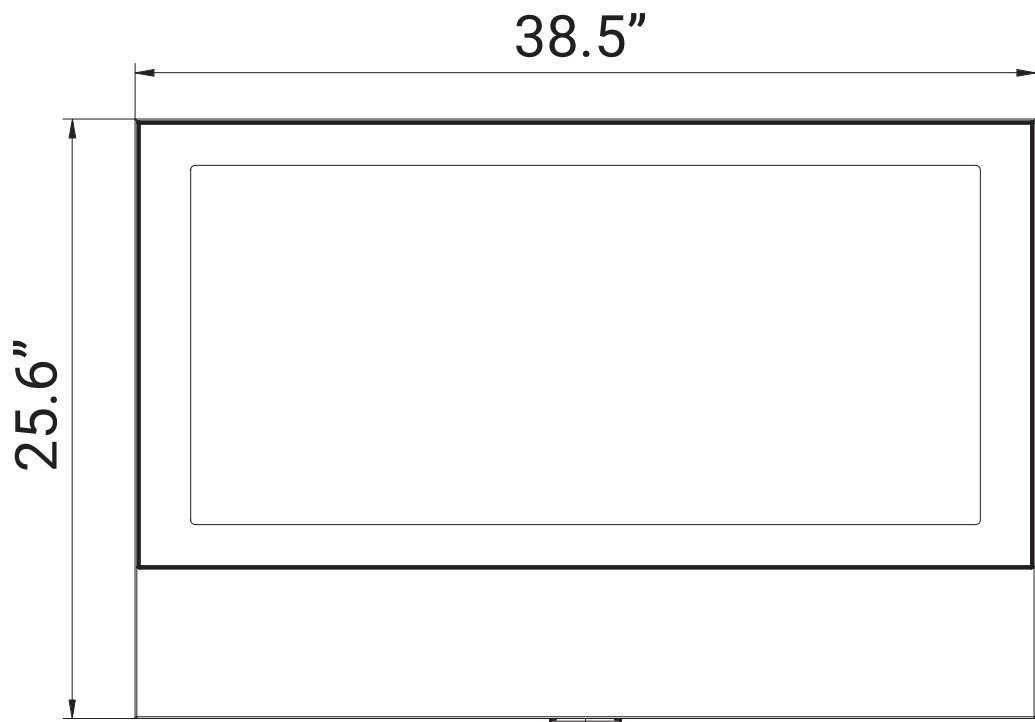

718-576-6342
info@koolmore.com

CERTIFICATIONS

