



SPEC SHEET

28 In. Stainless-Steel Professional Charcoal Oven with Warming Racks

Model: KM-CHO28-SS-TR

FEATURES

- **Commercial-Grade Charcoal Oven for High-Heat Cooking:** Designed for professional kitchens, delivering authentic charcoal flavor with high-temperature performance for grilling, roasting, and baking.
- **Efficient Charcoal System with 7.7 lbs. Capacity:** Optimized fuel capacity provides extended cooking time while maintaining consistent, high heat output.
- **Durable Stainless-Steel Construction:** Built with stainless steel exterior and reinforced interior components, ensuring long-lasting durability and easy cleaning.
- **Spacious Cooking Chamber with Multi-Rack Flexibility:** Includes 3 racks (2 standard cooking racks + 1 kebab rack), allowing versatile cooking configurations for a wide range of menu items.
- **Upper Warming Rack for Finishing and Heat Management:** Features a 27.7" x 23" upper rack, ideal for holding cooked items, finishing dishes, or managing multiple heat zones.
- **Advanced Ventilation and Spark Control System:** Engineered with adjustable air intake, upper vent control, and spark-reducing exhaust design for enhanced safety and precise temperature control.
- **Integrated Chimney for Efficient Exhaust Management:** Helps direct smoke and heat safely while maintaining optimal cooking conditions.
- **Compact Countertop Design for Flexible Placement:** Base-free design allows easy integration onto existing workstations or cooking lines.



CLOSE UP IMAGES

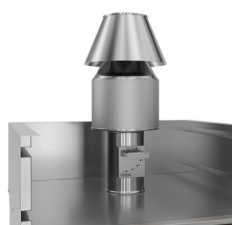

Technical Specs

Dimensions & Weight

Length	29.13 in.
Width	29.33 in.
Height	35.86 in.
Weight	462 lbs.
Interior Width	23.62 in.
Interior Depth	20.47 in.
Interior Height	18.11 in.
Depth With Door Open 90 Degrees	39.37 in.

Certifications

Certifications	NSF Certified for Sanitation
----------------	------------------------------

Capacity

Number of Oven Racks	5
Number of Grates	5
Fuel Capacity	7.72 lbs.

Features & Materials

Fuel Type	Charcoal
Number of Doors	1
Door Material	Cast Iron
Door Style	Vertical Downward Swing
Rack Positions	Oven: 4 Top Rack: 2
Preheat Time	30 mins
Burner Grates Material	Cast Iron
Commercial Residential	Commercial
Installation Type	Countertop
Ash Pan	Yes
Base Included	No
Dishwasher Safe Grates	No
Thermometer	No
Accessories Included	Tongs

Plan View

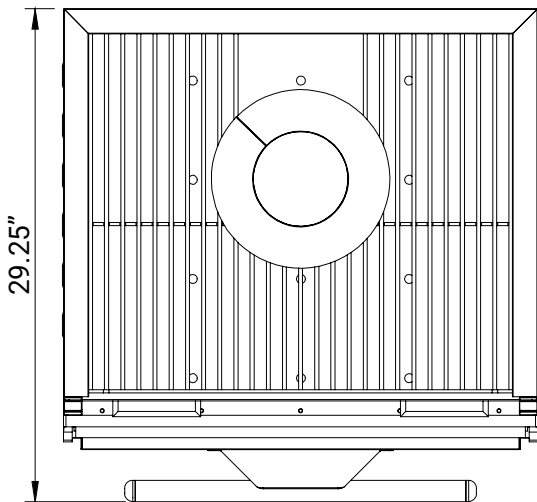
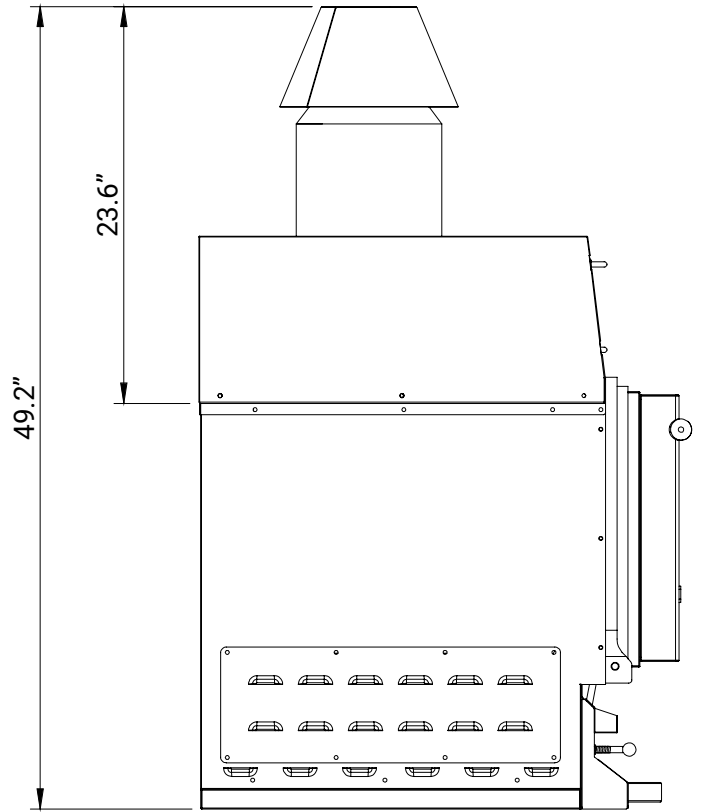
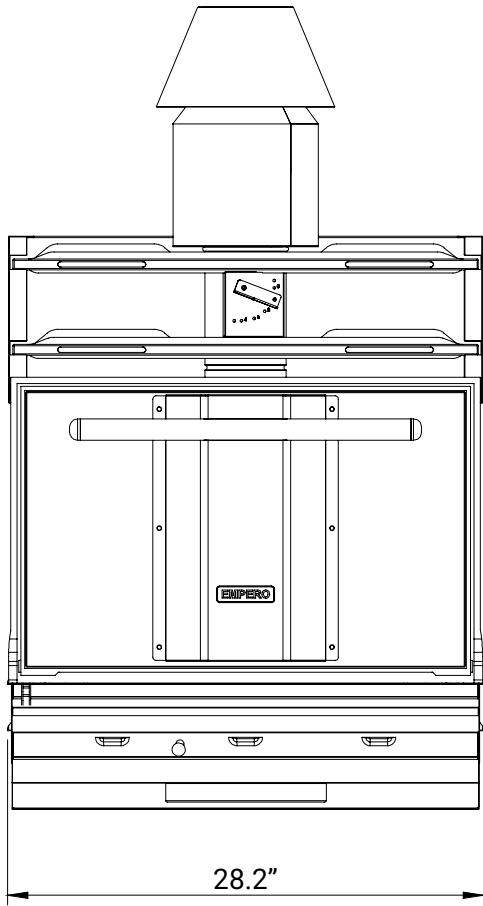

718-576-6342
info@koolmore.com

CERTIFICATIONS

