



SPEC SHEET

KoolMore 33 in. Commercial Insulated Heated Holding/Proofing Cabinet with Wire Racks and Solid Dutch Doors in with 16-Pan Capacity Silver

Model: KM-CHP36-WIDD

FEATURES

- Commercial Holding Cabinet
- Designed for Holding and proofing
- Aluminum Exterior
- Voltage: 120V
- Watts: 1500W
- UL and NSF Certifications



CLOSE UP IMAGES

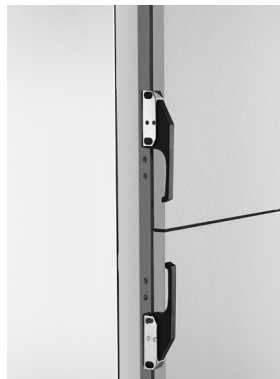

TECHNICAL SPECS

Dimensions

Length	33.4
Width	23.1
Height	67.5
Interior depth	27.2
Interior width	18.18
Interior height	53.88
Power cord length	102.36
Weightlbs	177.6

Capacity

Gross cubic feet	20.2
Net cubic feet	18.15

Features & materials

Control type	Mechanical
Temperature range	75-185 F
Number of doors	2
Hinge location	Top and Bottom
Rack positions	16
Pan capacity	16
Exhaust vent location	Bottom of the Rear of the Unit
Interior cabinet insulation	Cotton
Exterior material	Aluminum
Interior material	Aluminum
Glass type	NA
Color finish	Silver
Interior lights	No
Casters	4
Feature one	"4 Polyurethane Swivel Casters, 2 with Brakes"
Feature two	Full size insulated design holds up to 36 full size sheet pans; 1 1/2" of clearance between slides, heater & proofer, with wire racks, solid door 2 doors.

Electric & certification

Electrical installation type	Plug-in
Amps	14
Hertz	60
Phase	1
Voltage	120
Wattage	1500W
Plug type	Nema 5-15P
Certifications	UL Listed for Safety and NSF for Sanitation

Plan View

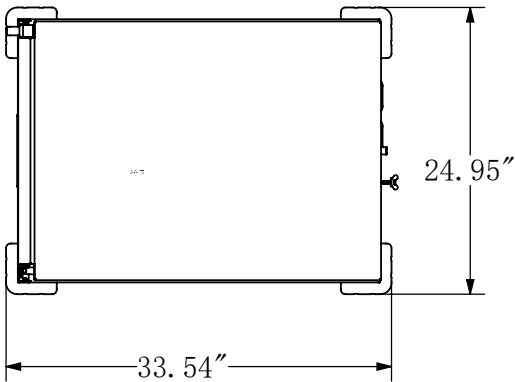
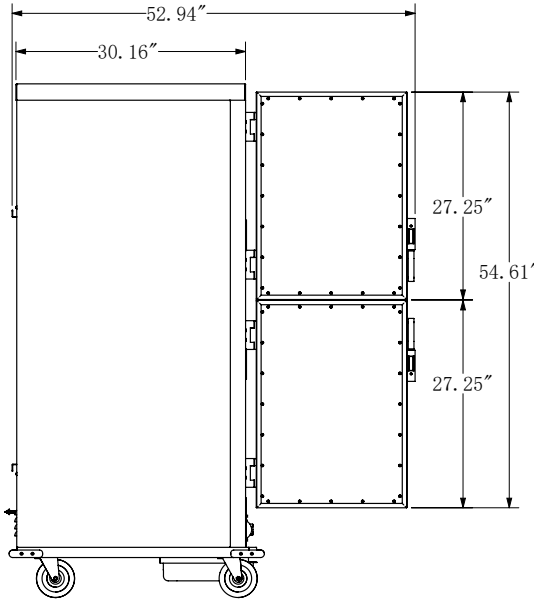
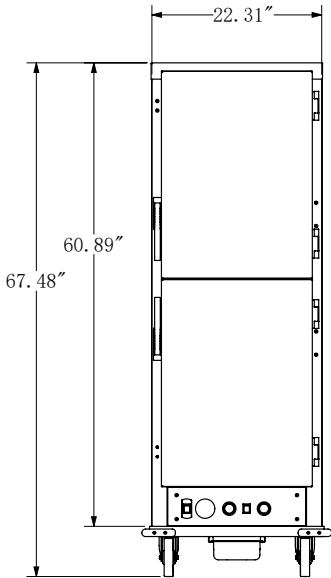
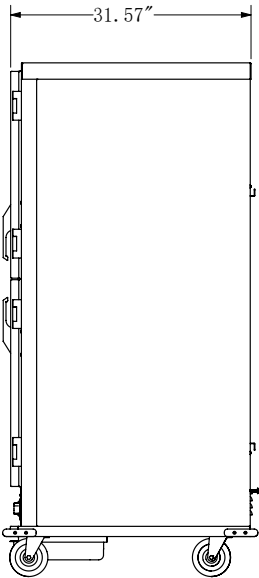

CERTIFICATIONS

UL NSF



706 Eastern Parkway STE 1G, Brooklyn NY 11213
718-576-6342
info@koolmore.com