



# SPEC SHEET

## KoolMore 50 lb. Floor Standing Natural Gas Commercial Fryer with 120,000 BTU in Stainless-Steel, ETL Listed

Model: KM-FDF50-NG

### FEATURES

- Commercial Natural Gas Deep Fryer
- Oil Capacity: 50 lbs.
- Number of Baskets: 2
- Number of Tubes: 4
- Stainless-Steel Finish
- 120,000 BTUs
- Temperature Range: 200-400°F



### CLOSE UP IMAGES

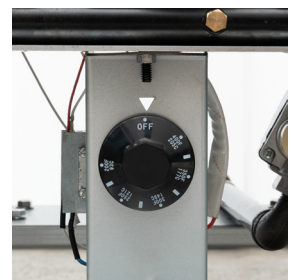
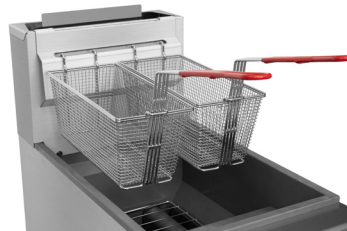
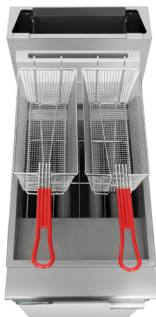

# TECHNICAL SPECS

## Dimensions

Length	15.6
Width	30.1
Height	45.8
Interior Width	14
Interior Depth	13.85
Interior Height	4.2
Weight Lbs	145

## Features & Materials

Oil Capacity	50lbs (22.5L)
Installation Type	Freestanding
Control Location	Inside the Cabinet at the Front
Number Of Temperature Cooking Controls	1
Number Of Burners	4
Cooking Area Sq	193.9
Temperature Range	200F-400 F
Number Of Baskets	2
Basket Lifts	Yes
Automatic Filtration	No
Exterior Material	Stainless-Steel 430
Interior Material	Stainless-Steel 439
Color Finish	Silver
Cooktop Surface Type	Stainless-Steel 430
Casters	
Number Of Feet	4
Legs Adjustable	Yes, 2 inches
Feature One	Large cold zone area
Feature Two	1-1/4" full port ball type drain valve
Feature Three	2 layer front door liner with overflow pipe holder
Feature Four	Thermostat control adjusts from 200° to 400 °F
Feature Five	Hi-limit shut-off protector shuts off gas combination valve and standing pilot
Feature Six	Built in flue deflector installed
Feature Seven	Removable stainless steel wire basket holder

## Fuel Info & Certifications

Fuel Type	NG
Convertible	Not Included
Gas Inlet Size	0.75
Diameter Of Drain Line Connection	1.25 in.
Btu Per Burner	30000
Number Of Tubes	4
Control Type	Manual
Certifications	ETL Listed for Safety and Sanitation

# Plan View

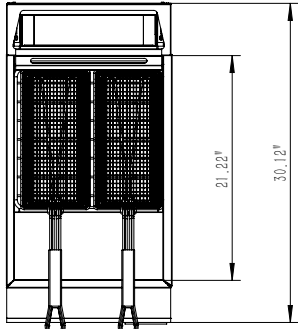
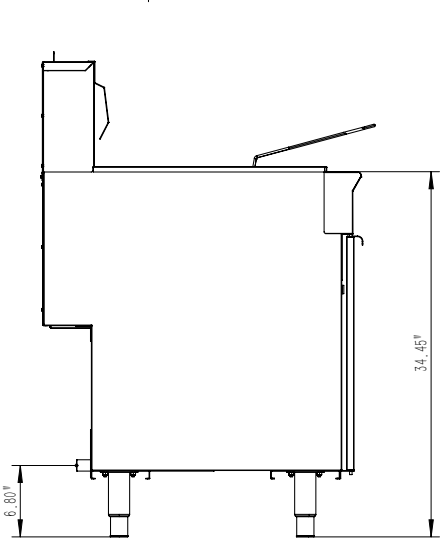
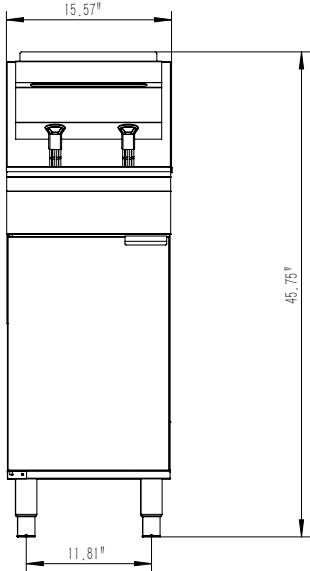

**CERTIFICATIONS**



Intertek Intertek



706 Eastern Parkway STE 1G, Brooklyn NY 11213  
718-576-6342  
info@koolmore.com