



SPEC SHEET

KoolMore 12" x 108" Stainless Steel Floor Trough Drain, 14-Gauge with Subway-Style Grating & Removable Drain Basket, NSF Listed

Model: KM-FTG-12108

FEATURES

- 14-gauge 304 stainless steel resists corrosion.
- Dual-drain design with 3-degree slope for fast flow.
- Subway-style grates handle heavy traffic and debris.
- Supports 1322 lbs. and holds 15.59 gallons.
- Two removable baskets for easy maintenance.
- Versatile 11 x 107 in. size fits most spaces.
- NSF certified with a 1-year warranty.



CLOSE UP IMAGES



TECHNICAL SPECS

Dimensions

Length	110
Width	14
Height	7
Interior Depth	12
Interior Width	108
Interior Height	4
Weight Lbs	158

Features & Materials

Top Capacity	1322 lbs.
Water Capacity	15.59 gal.
Exterior Material	Stainless-Steel 304
Gauge Of Stainless Steel	9 & 14
Color Finish	Stainless-Steel
Grate Thickness	
Diameter Of Drain Line Connection	4 in.
Included	2 Drain Baskets
Angle Of Downward Incline In Basin	3 degrees

Certification

Certifications	NSF Listed
----------------	------------

Plan View

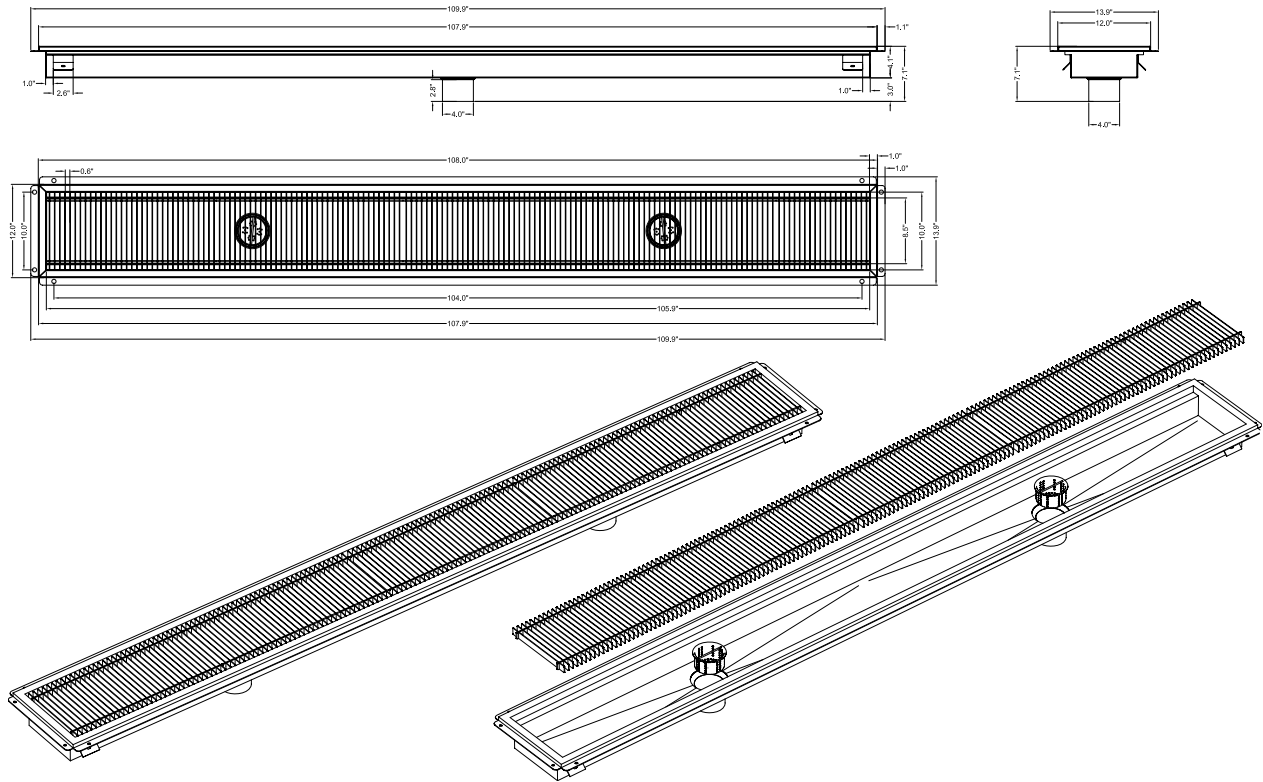

CERTIFICATIONS



706 Eastern Parkway STE 1G, Brooklyn NY 11213
718-576-6342
info@koolmore.com