



# SPEC SHEET

## KoolMore 12" x 120" Stainless Steel Floor Trough Drain, 14-Gauge with Subway-Style Grating & Removable Drain Basket, NSF Listed

---

Model: KM-FTG-12120

### FEATURES

---

- 14-gauge 304 stainless steel for corrosion resistance.
- Dual-drain with 3-degree slope ensures rapid drainage.
- Subway-style grates support heavy traffic and flow. Holds 1432 lbs. and 17.17 gallons of water.
- Two removable baskets simplify maintenance.
- Fits seamlessly with 11 x 119 in. dimensions.
- NSF certified with a 1-year warranty.

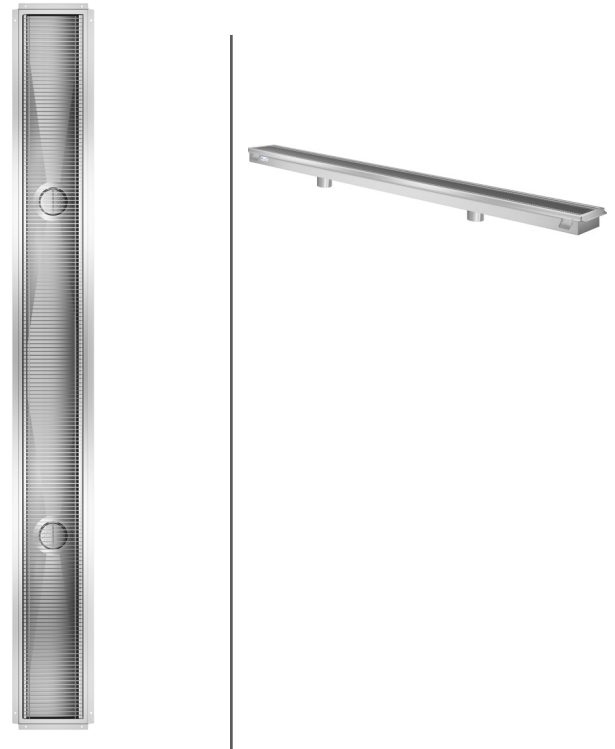

### CLOSE UP IMAGES

---



# TECHNICAL SPECS

## Dimensions

Length	122
Width	14
Height	7
Interior Depth	12
Interior Width	120
Interior Height	4
Weight Lbs	192

## Features & Materials

Top Capacity	1432 lbs.
Water Capacity	17.17 gal.
Exterior Material	Stainless-Steel 304
Gauge Of Stainless Steel	9 & 14
Color Finish	Stainless-Steel
Grate Thickness	
Diameter Of Drain Line Connection	4 in.
Included	2 Drain Baskets
Angle Of Downward Incline In Basin	3 degrees

## Certification

Certifications	NSF Listed
----------------	------------

# Plan View

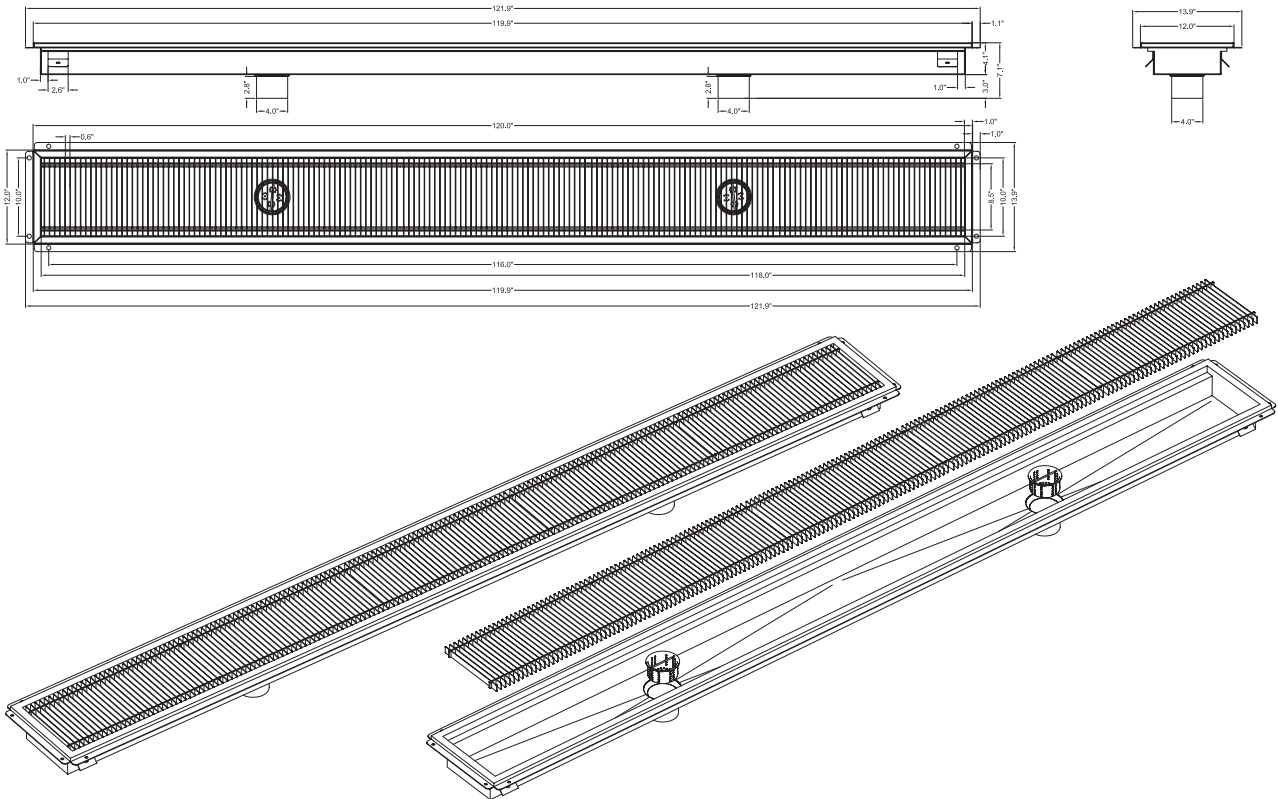

## CERTIFICATIONS



706 Eastern Parkway STE 1G, Brooklyn NY 11213  
718-576-6342  
info@koolmore.com