

# **MIDEA SERVICE MANUAL**

## **MICROWAVE OVEN**

**Type: OVER THE RANGE**

**December, 2017**

This document is published to be used for after sales service only. The content are subject to change without prior notice.  
In interest of user safety the appliance should be restored to its original condition and only parts identical to those should be applied.

# CONTENTS

CAUTIONS .....	1
SERVICE INFORMATION .....	2
Grounding Instructions .....	2
Microwave Leakage Test .....	2
Description And Function Of Component .....	3
COMPONENT TEARDOWN .....	4
1. Hood Exhaust Louver Removal .....	4
2. Removal of Oven From Wall .....	4
3. Outer Case Removal .....	4
4. High Voltage Transformer Removal .....	5
5. High Voltage Diode And High Voltage Capacitor Removal .....	5
6. Magnetron Removal .....	5
7. Hood Fan Thermal Cut-Out Removal .....	5
8. Hood Fan Motor Removal .....	6
9. Thermal Cut-Out(Cavity) Removal .....	6
10. Cooling Fan Motor Removal .....	6
11. Turntable Motor And Hood Lamp Sockets Removal .....	6
12. Oven Lamp And Lamp Sockets Removal .....	6
13. Control Assembly Removal .....	7
14. Stirrer Motor Removal .....	7
15. Stirrer Bracket And Stirrer Fan Removal .....	7
16. Door Assembly Removal .....	7
17. Sensor Humidity Removal .....	7
18. Convection Motor Removal .....	8
19. Thermal Cut-Out(Convection) Removal .....	8
TROUBLESHOOTING AND TESTING .....	9
1. Troubleshooting Guide Chart .....	9
2. Test Procedures .....	10
ATTACHED FILES LIST .....	19

# CAUTIONS

THE OVEN IS TO BE SERVICED ONLY BY PROPERLY QUALIFIED SERVICE PERSONNEL.

## WARNING TO SERVICE PERSONNEL

Microwave ovens contain circuitry capable of producing very high voltage and current, contact with following parts may result in a severe, possibly fatal, electrical shock.

(Example)

High Voltage Capacitor, High Voltage Power Transformer, Magnetron, High Voltage Rectifier Assembly, High Voltage Harness etc..

Read the Service Manual carefully and follow all instructions.

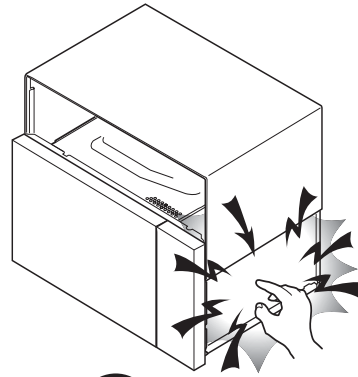

**Don't Touch !  
Danger High Voltage**

### Before Servicing



1. Disconnect the power supply cord , and then remove outer case.
2. Open the door and block it open.
3. Discharge high voltage capacitor.

#### **WARNING: RISK OF ELECTRIC SHOCK. DISCHARGE THE HIGH-VOLTAGE CAPACITOR BEFORE SERVICING.**

The high-voltage capacitor remains charged about 60 seconds after the oven has been switched off. Wait for 60 seconds and then short-circuit the connection of the high-voltage capacitor (that is the connecting lead of the high-voltage diode) against the chassis with the use of an insulated screwdriver.

Whenever troubleshooting is performed the power supply must be disconnected. It may, in some cases, be necessary to connect the power supply after the outer case has been removed, in this event,

1. Disconnect the power supply cord, and then remove outer case.
2. Open the door and block it open.
3. Discharge high voltage capacitor.
4. Disconnect the leads to the primary of the power transformer.
5. Ensure that these leads remain isolated from other components and oven chassis by using insulation tape.
6. After that procedure, reconnect the power supply cord.

### When the testing is completed,

1. Disconnect the power supply cord, and then remove outer case.
2. Open the door and block it open.
3. Discharge high voltage capacitor.
4. Reconnect the leads to the primary of the power transformer.
5. Reinstall the outer case (cabinet).
6. Reconnect the power supply cord after the outer case is installed.
7. Run the oven and check all functions.

### After repairing

1. Reconnect all leads removed from components during testing.
2. Reinstall the outer case (cabinet).
3. Reconnect the power supply cord after the outer case is installed.
4. Run the oven and check all functions.

Microwave ovens should not be run empty. To test for the presence of microwave energy within a cavity, place a cup of cold water on the oven turntable, close the door and set the power to HIGH and set the microwave timer for two (2) minutes. When the two minutes has elapsed (timer at zero) carefully check that the water is now hot. If the water remains cold carry out **Before Servicing** procedure and re-examine the connections to the component being tested.

When all service work is completed and the oven is fully assembled, the microwave power output should be checked and microwave leakage test should be carried out.

# SERVICE INFORMATION

## Grounding Instructions

This oven is equipped with a three prong grounding plug. It must be plugged into a wall receptacle that is properly installed and grounded in accordance with the National Electrical Code, local codes and ordinances. In the event of an electrical short circuit, grounding reduces the risk of electric shock by providing an escape wire for the electric current.

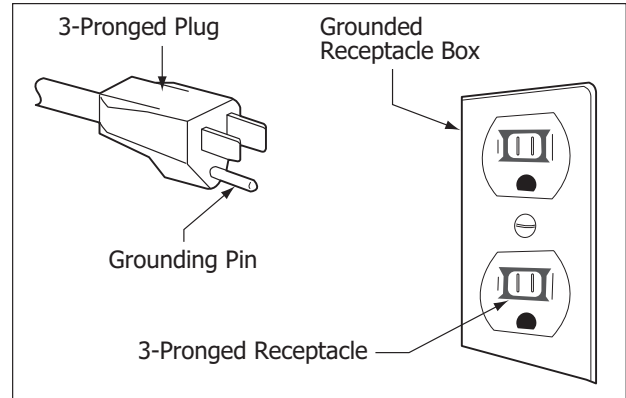

## Microwave Leakage Test

### CAUTIONS

- Be sure to check microwave leakage prior to servicing the oven if the oven is operative prior to servicing.
- The service personnel should inform the manufacture importer, or assembler of any certified oven unit found to have a microwave emission level in excess of  $5 \text{ mW/cm}^2$  and should repair any unit found to have excessive emission levels at no cost to the owner and should ascertain the cause of the excessive leakage. The service personnel should instruct the owner not to use the unit until the oven has been brought into compliance.
- If the oven operates with the door open, the service personnel should:
  - Tell the user not to operate the oven.
  - Contact the manufacturer.
- The service personnel should check all surface and vent openings for microwave leakage.
- Check for microwave leakage after every servicing. The power density of the microwave radiation leakage emitted by the microwave oven should not exceed  $4 \text{ mW/cm}^2$ . Always start measuring of an unknown field to assure safety for operating personnel from radiation leakage.

### MEASURING MICROWAVE ENERGY LEAKAGE

- Pour  $275 \pm 15 \text{ cc}$  of  $20 \pm 5^\circ\text{C}$  ( $68 \pm 9^\circ\text{F}$ ) water in a beaker which is graduated to 600 cc, and place the beaker on the center of the turntable.
- Set the energy leakage monitor to 2450 MHz and use it following the manufacturer's recommended test procedure to assure correct result.
- When measuring the leakage, always use the 2-inch (5cm) spacer supplied with the probe.
- Operate the oven at its maximum output.
- Measure the microwave radiation using and electromagnetic radiation monitor by holding the probe perpendicular to the surface being measured

Move probe along shaded area

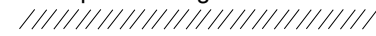

Probe scanning speed  
Less than  $2.5 \text{ cm/sec}$   
(  $1 \text{ in/sec}$  )

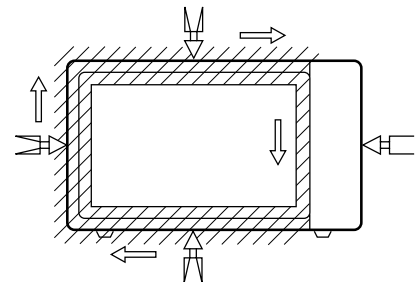

# Description And Function Of Component

## DOOR OPEN MECHANISM

The door is opened by pulling the door handle, refer to the Figure D-1.

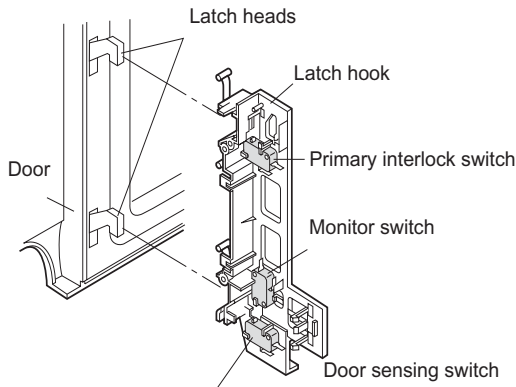

Figure D-1. Door Open Mechanism

## DOOR SENSING SWITCH, PRIMARY INTERLOCK SWITCH

The primary interlock switch is mounted in the upper position of the latch hook, the door sensing switch in the primary interlock system is mounted in the lower position of the latch hook. They are activated by the latch heads on the door. When the door is opened, the switches interrupt the circuit to all components. A cook cycle cannot take place until the door is firmly closed thereby activating both interlock switches. The primary interlock system consists of the door sensing switch and secondary interlock relay located on the control circuit board.

## MONITOR SWITCH

The monitor switch is activated (the contacts opened) by the latch head on the door while the door is closed. The switch is intended to render the oven inoperative, by means of blowing the monitor fuse, when the contacts of the secondary interlock relay (RY2) and primary interlock switch fail to open when the door is opened.

### Functions:

1. When the door is opened, the monitor switch contact close (to the ON condition) due to their being normally closed. At this time the secondary interlock relay (RY2), primary interlock switch are in the OFF condition (contacts open) due to their being normally open contact switches. And the contacts of relay (RY1) are in the ON condition (contacts close).
2. As the door goes to a closed position, the monitor switch contacts are first opened and then the door sensing switch and the primary interlock switch contacts close. (On opening the door, each of these switches operate inversely.)
3. If the door is opened, and the secondary interlock relay (RY2) and primary interlock switch contacts fail to open, the monitor fuse blows simultaneously with closing of the

**CAUTION:** BEFORE REPLACING A BLOWN MONITOR FUSE TEST THE DOOR SENSING SWITCH, SECONDARY INTERLOCK RELAY (RY2), RELAY (RY1), PRIMARY INTERLOCK SWITCH AND MONITOR SWITCH FOR PROPER OPERATION. (REFER TO CHAPTER "TEST PROCEDURE").

**NOTE:** MONITOR FUSE AND MONITOR SWITCH ARE REPLACED AS AN ASSEMBLY.

## THERMAL CUT-OUT (HOOD )

This thermal cut-out located on the right base plate. It is designed to automatically turn on the hood fan motor whenever the hot air rising from the conventional range below causes the temperature at the thermal cut-out to rise to 158°F (70°C) or higher, thus removing this hot air from around microwave oven. When the temperature around the thermal cut-out drops to 104°F (40°C) or lower, the thermal cut-out shuts off the hood fan motor.

## THERMAL CUT-OUT (CAVITY )

This thermal cut-out is located on the top of the oven cavity. It is designed to prevent damage to the oven unit if the food in the oven catches fire due to overheating produced by improper setting of cooking time or failure of control unit. Under normal operation, the thermal cut-out remains closed. However, the thermal cut-out will open at 230°F (110°C) causing the oven to shut down.

## TURNTABLE MOTOR

The turntable motor rotates the turntable located on the bottom of the oven cavity, so that the foods on the turntable cook evenly during cooking. Turntable will turn in either direction.

## COOLING FAN MOTOR

The cooling fan motor drives a blade which draws external cool air. This cool air is directed through the air vanes surrounding the magnetron and cools the magnetron. This air is channelled through the oven cavity to remove steam and

vapors given off from the heating foods. It is then exhausted through the exhausting air vents at the oven cavity.

## HOOD FAN MOTOR

The hood fan motor is a two-speeds, single-phase, double pole induction type, requiring a hood fan capacitor. It is located outside the upper rear part of the oven cavity, is to remove, from around the oven, hot air rising from the conventional electric or gas range over which it is installed. This air is then expelled either vertically or horizontally through the customer supplied duct system, or discharged back into the kitchen.

## HOOD LAMP

The hood lamps are mounted at the hood lamp angle on the base cover. The hood lamps can be turned off and on.

# COMPONENT TEARDOWN

## CAUTION

1. **Disconnect oven from power supply before removing outer case.**
2. **Discharge the high voltage capacitor before touching any oven components or wiring.**

## NOTE

To discharge the high voltage capacitor, wait for 60 seconds and then short-circuit the connection of the high-voltage capacitor (that is the connecting lead of the high-voltage diode) against the chassis with the use of an insulated screwdriver.

### 1. Hood Exhaust Louver Removal

Remove the oven from the wall and proceed as follows:

1. Disconnect the power supply cord.
2. Open the door and block it open.
3. To discharge the high voltage capacitor, wait for 60sec.
4. Remove the screws on the top holding the hood exhaust louver to the oven cavity front face plate.
5. Pull the hood exhaust louver from the oven cavity by pushing the left tab of the hood exhaust louver to remove.
6. Now, the hood exhaust louver is free.

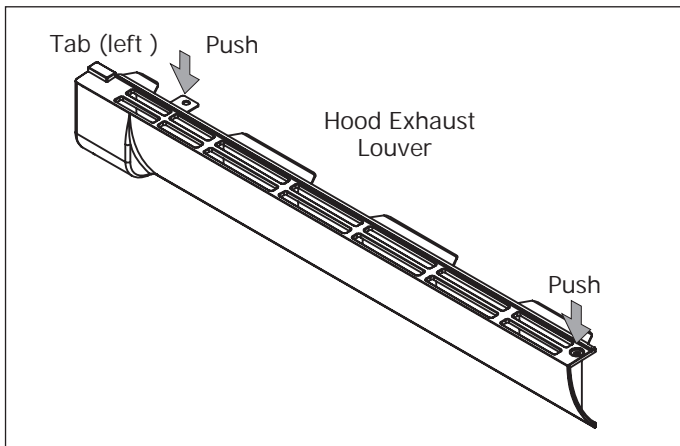

### 2. Removal Of Oven From Wall

## NOTE

Two persons are recommended to remove the oven from a wall installation.

1. Disconnect the power supply cord, and uncoil the power supply cord.
2. To discharge the high voltage capacitor, wait for 60sec.
3. Remove the turntable tray and support from the oven cavity.
4. Remove the three (3) screws holding the oven (outer case cabinet) to the top cabinet.
5. While supporting the front of the oven, and release the oven from the unit mounting plate.
6. Pull the power cord out of the wall cabinet and remove the oven.
7. The oven is now free and can be placed on the work surface selected for servicing the oven.
8. Installation is the reverse of this procedure.

### 3. Outer Case Removal

Remove the oven from the wall and proceed as follows:

1. Disconnect the power supply cord.
2. Open the door and block it open.
3. To discharge the high voltage capacitor, wait for 60sec.
4. Remove screws holding the top stay to the hood fan motor or the oven, and remove it.
5. Remove the seven (7) screws from the rear of the outer case cabinet and two (2) screws at right, and five (5) screws at top, and four (4) screws at bottom.
6. Slide the outer case cabinet back to free it from retaining clips on the cavity face plate.
7. Now, the outer case is free.

#### 4. High Voltage Transformer Removal

1. Disconnect the power supply cord, remove oven from wall, then remove outer case.
2. Open the door and block it open.
3. Discharge high voltage capacitor.
4. Remove the screws holding the base plate to the oven cavity and outer case on the bottom, disconnect the wires from turntable motor and two cooktop lamps. And remove the base plate.
5. Disconnect main wire harness from transformer.
6. Disconnect high voltage wire from the transformer.
7. Disconnect filament leads of transformer from the magnetron and capacitor.
8. Remove the screws holding the transformer to bottom plate.

#### 5. High Voltage Diode And High Voltage Capacitor Removal

1. Disconnect the power supply cord, remove oven from wall, then remove outer case.
2. Open the door and block it open.
3. Discharge high voltage capacitor.
4. Disconnect the high voltage wire lead with high voltage diode from the magnetron.
5. Disconnect filament lead of the transformer from high voltage capacitor.
6. Disconnect high voltage wire from capacitor.
7. Remove the screw holding capacitor holder and another screw holding high voltage diode to the back wind guide.
8. Disconnect the high voltage diode assembly from the high voltage capacitor.
9. The high voltage diode assembly is now free. Remove capacitor from the holder.
10. The high voltage capacitor is now free.

#### 6. Magnetron Removal



#### CAUTION

**When replacing the magnetron, be sure the R.F. Gasket is in place and mounting screws are tightened securely.**

1. Disconnect the power supply cord, remove oven from wall, then remove outer case.
2. Open the door and block it open.
3. Discharge high voltage capacitor.
4. Disconnect the high voltage wire lead of the high voltage diode assembly from the magnetron.
5. Disconnect the filament lead of the transformer from the magnetron.
6. Carefully remove mounting screws holding magnetron to waveguide. When removing the screws, hold magnetron to prevent it from falling.
7. Remove the magnetron from the unit with care so the magnetron tube should not be hit by any metal object around the tube.

#### 7. Hood Fan Thermal Cut-Out Removal

1. Disconnect the power supply cord, remove Hood Exhaust Louver.
2. Open the door and block it open.
3. Remove the screw holding the control panel to the oven cavity front plate.
4. Push up the control panel and remove it from cavity and hold it at the front plate by the control panel flange. Disconnect wire leads from control panel.
5. Disconnect wire leads from hood fan thermal cut-out.
6. Remove screw holding the thermal cut-out to the bottom plate (outer case side).
7. Remove the hood fan thermal cut-out from the bottom plate.

## **8 Hood Fan Motor Removal**

1. Disconnect the power supply cord, remove oven from wall, then remove outer case.
2. Open the door and block it open.
3. Discharge high voltage capacitor.
4. Disconnect the 6-pin connector of the hood fan motor from the main wire harness located at the right edge of the hood duct and release the snap band from the hood duct. Remove one (1) screw holding the Hood fan motor on the rear cavity.
5. Remove hood fan motor from the oven cavity top plate by lifting it up. Hood fan motor is now free.

## **9 Thermal Cut-Out (Cavity) Removal**

1. Disconnect the power supply cord, remove oven from wall, then remove outer case.
2. Open the door and block it open.
3. Discharge high voltage capacitor.
4. Disconnect the wire leads from the thermal cut-out (cavity).
5. Remove the thermal cut-out (cavity) from the holder at the air duct.

## **10. Cooling Fan Motor Removal**

1. Disconnect the power supply cord, remove oven from wall, then remove outer case.
2. Open the door and block it open.
3. Discharge high voltage capacitor.
4. Disconnect the wire leads from the fan motor.
5. Remove the one (1) screws holding the fan guide to back wind guide.
6. Push up the fan guide and remove it from back wind guide.
7. Remove two (2) screws holding the fan motor to fan guide.
8. Remove the fan motor from the fan guide and the fan blade by pulling the fan motor with your hand. The fan blade will fall as the motor is removed.

## **11. Turntable Motor And Hood Lamp Sockets Removal**

1. Disconnect the power supply cord.
2. Open the door and block it open.
3. Remove the screws holding the bottom guide plate to the oven cavity front face plate.
4. Remove the screws holding the base plate to the bottom of cavity and outer case.
5. The base plate is now hanging on the rear cavity.

### **TURNTABLE MOTOR**

6. Disconnect the wire leads from the turntable motor.
7. Remove the screw holding turntable motor to the oven cavity.
8. The turntable motor is now free.

### **HOOD LAMP SOCKET**

9. Disconnect the wire leads from the lamp socket.
10. Remove the two lamp covers and remove the screws holding the lamp socket to the base plate. Remove the lamps. The lamp socket is now free.

## **12. Oven Lamp And Lamp Socket Removal**

1. Disconnect the power supply cord, remove the hood exhaust louver.
2. Remove the screws holding the lamp cover to the oven cavity front flange, then remove the lamp cover.
3. Disconnect the wire leads from lamp socket.
4. Turn the oven lamp out from the lamp socket.
5. Turn the hooks of lamp socket bracket and release the lamp socket.

### 13. Control Assembly Removal

1. Disconnect the power supply cord.
2. Open the door and block it open.
3. Discharge high voltage capacitor.
4. Remove the screws holding the hood exhaust louver to oven cavity front face plate.
5. Remove the hood exhaust louver from the oven by pushing the left tabs of the hood exhaust louver.
6. Remove the screw holding the control panel to the oven cavity front face plate.
7. Release the control panel from the oven cavity front face plate by lifting it up.
8. Disconnect the wire leads from the relays.
9. Disconnect the connectors from the control unit.
10. Remove the control assembly from the oven.
11. Now, the control assembly is free.
12. Remove the screws holding the PCB to the control panel.
13. The PCB is now free.

### 14. Stirrer Motor Removal

1. Disconnect the power supply cord, remove oven from wall, then remove outer case.
2. Open the door and block it open.
3. Discharge high voltage capacitor.
4. Remove the screw holding the lamp cover to the oven cavity front flange, then remove the lamp cover.
5. Disconnect the wire lead from the stirrer motor.
6. Remove the screws holding the stirrer motor to the cavity.
7. Now, the stirrer motor is free.

### 15. Stirrer Bracket and Stirrer Fan Removal

1. Disconnect the power supplier cord.
2. Open the door and block it open.
3. Remove the plastic nail with '—' driver.
4. Counterclockwise rotate the stirrer bracket.
5. Now the stirrer bracket and stirrer fan is free.

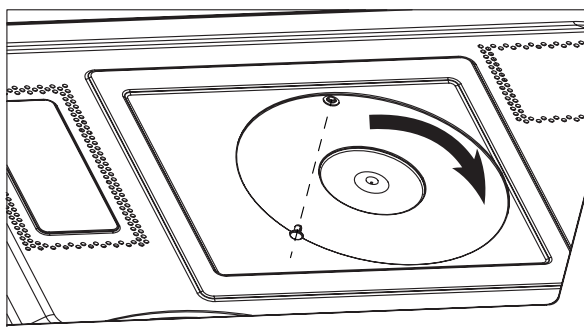

### 16. Door Assembly Removal

1. Disconnect the power supply cord.
2. Open the door and block it open.
3. To discharge the high voltage capacitor.
4. Remove the screws holding the hood exhaust louver to the oven cavity front face plate.
5. Remove the hood exhaust louver from the oven cavity by pushing the right and left tabs of the hood exhaust louver.
6. Disconnect wire lead from the top left corner of cavity.
7. Lift up the door assembly to release the upper and lower door hinge pins from the upper and lower oven hinges. Door assembly is now free.

### 17. Sensor Humidity Removal

1. Disconnect the power supply cord, remove oven from wall, then remove outer case.
2. Open the door and block it open.
3. Discharge high voltage capacitor.
4. Remove the screw holding the control panel to the oven cavity front plate.
5. Push up the control panel and remove it from cavity and hold it at the front plate by the control panel flange.
6. Disconnect the wire leads from the control panel.
7. Remove the screw holding the hood motor to cavity and remove the hood motor.
8. Remove the screws from the air duct to cavity.
9. Remove the screw from the air grid \*R to cavity and remove the air grid \*R.
10. Remove the screws from the air duct to fan guide.
11. Remove the screws from the air duct to back wind guide.
12. Remove the screw from power cord to back wind guide.
13. Remove the screw from earth connection of noise filter to cavity.
14. Disconnect the wire leads from the air duct assembly.
15. Now, the air duct assembly is free.
16. Remove the screws from sensor humidity to air duct.
17. Now, the sensor humidity is free.

## **18. Convection Motor Removal**

1. Disconnect the power supply cord, remove oven from wall, then remove outer case.
2. Open the door and block it open.
3. Discharge high voltage capacitor.
4. Disconnect the wire lead from convection motor.
5. Remove the belt.
6. Remove the screws holding motor bracket connector to the main wind guide.
7. Remove the screws holding motor bracket to cavity.
8. Remove the screws holding the motor to the motor bracket.
9. Remove one nut holding pulley to the motor.
10. The convection motor is now free.

## **19. Thermal Cut-Out (Convection) Removal**



1. Disconnect the power supply cord, remove oven from wall, then remove outer case.
2. Open the door and block it open.
3. Discharge high voltage capacitor.
4. Disconnect the wire lead from thermal cut-out.
5. Release the thermal cut-out from the convection assembly.
6. Now, the thermal cut-out is free.



# Test Procedures

Procedure Letter	Component Test
A	<p><b>MAGNETRON ASSEMBLY TEST</b></p> <div style="background-color: #e0e0e0; padding: 5px; border: 1px solid black;"> <p> <b>WARNING</b></p> <p><b>High voltages are present during the cook cycle, so extreme caution should be observed. Discharge the high voltage capacitor before touching any oven components or wiring.</b></p> </div> <ol style="list-style-type: none"> <li>1. Disconnect the power supply cord, and then remove outer case.</li> <li>2. Open the door and block it open.</li> <li>3. Discharge high voltage capacitor.</li> <li>4. To test for an open filament, isolate the magnetron from the high voltage circuit. A continuity check across the magnetron filament leads should indicate less than 1 ohm.</li> <li>5. To test for a shorted magnetron, connect the ohmmeter leads between the magnetron filament leads and chassis ground. This test should indicate an infinite resistance. If there is little or no resistance the magnetron is grounded and must be replaced.</li> <li>6. Reconnect all leads removed from components during testing.</li> <li>7. Reinstall the outer case (cabinet).</li> <li>8. Reconnect the power supply cord after the outer case is installed.</li> <li>9. Run the oven and check all functions.</li> </ol> <p><b>MICROWAVE OUTPUT POWER</b></p> <p>Power output of the magnetron can be measured by performing a water temperature rise test. This test should only be used if above tests do not indicate a faulty magnetron and there is no defect in the following components or wiring: silicon rectifier, high voltage capacitor and power transformer. This test will require a 16 ounce (453 cc.) measuring cup and an accurate mercury thermometer or thermocouple type temperature tester. For accurate results, the following procedure must be followed carefully:</p> <ol style="list-style-type: none"> <li>1. Fill the measuring cup with 16 oz. (453 cc.) of tap water and measure the temperature of the water with a thermometer or thermocouple temperature tester. Stir the thermometer or thermocouple through the water until the temperature stabilizes. Record the temperature of the water.</li> <li>2. Place the cup of water in the oven. Operate oven at 100% POWER selecting more than 60 seconds cook time. Allow the water to heat for 60 seconds, measuring with a stop watch, second hand of a watch or the digital read-out countdown.</li> <li>3. Remove the cup from the oven and again measure the temperature, making sure to stir the thermometer or thermocouple through the water until the maximum temperature is recorded.</li> <li>4. Subtract the cold water temperature from the hot water temperature. The normal result should be 29.2 to 54.2°F (16.2 to 30.1°C) rise in temperature. If the water temperatures are accurately measured and tested for the required time period the test results will indicate if the magnetron tube has low power output (low rise in water temperature) which would extend cooking time or high power output (high rise in water temperature) which would reduce cooking time. Because cooking time can be adjusted to compensate for power output, the magnetron tube assembly should be replaced only if the water temperature rise test indicates a power output well beyond the normal limits. The test is only accurate if the power supply line voltage is 120 volts and the oven cavity is clean.</li> </ol>

# Test Procedures

Procedure Letter	Component Test
<p><b>B</b></p>	<p><b>POWER TRANSFORMER TEST</b></p> <div style="background-color: #e0e0e0; padding: 5px; border: 1px solid #ccc;"> <p> <b>WARNING</b></p> <p><b>Do not touch the components of the power transformer while power transformer is energized. It is dangerous because this has high voltage components. (High voltages are present at the high voltage terminal, so do not attempt to measure the filament and high voltage.)</b></p> </div> <ol style="list-style-type: none"> <li>1. Disconnect the power supply cord, and then remove outer case.</li> <li>2. Open the door and block it open.</li> <li>3. Discharge high voltage capacitor.</li> <li>4. Disconnect the primary input terminals and measure the resistance of the transformer with an ohmmeter. Check for continuity of the coils with an ohmmeter. On R x 1 scale, the resistance of the primary coil should be less than 1 ohm and the resistance of the high voltage coil should be approximately 83 ohms; the resistance of filament coil should be less than 1 ohm.</li> <li>5. Reconnect all leads removed from components during testing.</li> <li>6. Reinstall the outer case (cabinet).</li> <li>7. Reconnect the power supply cord after the outer case is installed.</li> <li>8. Run the oven and check all functions.</li> </ol>
<p><b>C</b></p>	<p><b>HIGH VOLTAGE RECTIFIER TEST</b></p> <ol style="list-style-type: none"> <li>1. Disconnect the power supply cord, and then remove outer case.</li> <li>2. Open the door and block it open.</li> <li>3. Discharge high voltage capacitor.</li> <li>4. Isolate the rectifier from the circuit. Using the highest ohm scale of the meter, read the resistance across the terminals and observe, reverse the leads to the rectifier terminals and observe meter reading. If a short is indicated in both directions, or if an infinite resistance is read in both directions, the rectifier is probably defective and should be replaced.</li> <li>5. Reconnect all leads removed from components during testing.</li> <li>6. Reinstall the outer case (cabinet).</li> <li>7. Reconnect the power supply cord after the outer case is installed.</li> <li>8. Run the oven and check all functions.</li> </ol> <div style="background-color: #e0e0e0; padding: 5px; border: 1px solid #ccc;"> <p> <b>NOTE</b></p> <p>Be sure to use an ohmmeter that will supply a forward bias voltage of more than 9.0 volts.</p> </div>

# Test Procedures

Procedure Letter	Component Test
<p><b>D</b></p>	<p><b>HIGH VOLTAGE CAPACITOR TEST</b></p> <ol style="list-style-type: none"> <li>1. Disconnect the power supply cord, and then remove outer case.</li> <li>2. Open the door and block it open.</li> <li>3. Discharge high voltage capacitor.</li> <li>4. If the capacitor is open, no high voltage will be available to the magnetron. Disconnect input leads and check for short or open between the terminals using an ohmmeter. Checking with a high ohm scale, if the high voltage capacitor is normal, the meter will indicate continuity for a short time and should indicate an open circuit once the capacitor is charged. If the above is not the case, check the capacitor with an ohmmeter to see if it is shorted between either of the terminals and case. If it is shorted, replace the capacitor.</li> <li>5. Reconnect all leads removed from components during testing.</li> <li>6. Reinstall the outer case (cabinet).</li> <li>7. Reconnect the power supply cord after the outer case is installed.</li> <li>8. Run the oven and check all functions.</li> </ol>
<p><b>E</b></p>	<p><b>CAVITY THERMAL CUT-OUT TEST</b></p> <ol style="list-style-type: none"> <li>1. Disconnect the power supply cord, and then remove outer case.</li> <li>2. Open the door and block it open.</li> <li>3. Discharge high voltage capacitor.</li> <li>4. A continuity check across the thermal cut-out terminals should indicate a closed circuit unless the temperature of the thermal cut-out reaches approximately 302°F(150°C). An open thermal cut-out indicates overheating of the oven, exchange thermal cut-out and check inside of oven cavity for improper setting of cooking time or operation of control unit. Check for restricted air flow through the vent holes of the oven cavity, especially the cooling fan and air guide.</li> <li>5. Reconnect all leads removed from components during testing.</li> <li>6. Reinstall the outer case (cabinet).</li> <li>7. Reconnect the power supply cord after the outer case is installed.</li> <li>8. Run the oven and check all functions.</li> </ol> <p><b>MAGNETRON TEMPERATURE FUSE TEST</b></p> <ol style="list-style-type: none"> <li>1. Disconnect the power supply cord, and then remove outer case.</li> <li>2. Open the door and block it open.</li> <li>3. Discharge high voltage capacitor.</li> <li>4. A continuity check across the magnetron temperature fuse terminals should indicate a closed circuit unless the temperature of the magnetron temperature fuse reaches approximately 302°F (150°C). An open magnetron temperature fuse indicates overheating of the magnetron. Check for restricted air flow to the magnetron, especially the cooling fan air guide.</li> <li>5. Reconnect all leads removed from components during testing.</li> <li>6. Reinstall the outer case (cabinet).</li> <li>7. Reconnect the power supply cord after the outer case is installed.</li> <li>8. Run the oven and check all functions.</li> </ol> <div style="background-color: #cccccc; padding: 5px; margin-top: 10px;"> <p> <b>CAUTION</b></p> </div> <div style="border: 1px solid black; padding: 5px; margin-top: 5px;"> <p><b>If the temperature fuse indicates an open circuit at room temperature, replace temperature fuse.</b></p> </div>

# Test Procedures

Procedure Letter	Component Test
F	<p><b>PRIMARY INTERLOCK SWITCH TEST</b></p> <ol style="list-style-type: none"> <li>1. Disconnect the power supply cord, and then remove outer case.</li> <li>2. Open the door and block it open.</li> <li>3. Discharge high voltage capacitor.</li> <li>4. Isolate the switch and connect the ohmmeter to the common (COM.) and normally open (NO) terminal of the switch. The meter should indicate an open circuit with the door open and a closed circuit with the door closed. If improper operation is indicated, replace the primary interlock switch.</li> <li>5. Reconnect all leads removed from components during testing.</li> <li>6. Reinstall the outer case (cabinet).</li> <li>7. Reconnect the power supply cord after the outer case is installed.</li> <li>8. Run the oven and check all functions.</li> </ol>
G	<p><b>PRIMARY INTERLOCK SYSTEM TEST</b></p> <p><b>DOOR SENSING SWITCH</b></p> <ol style="list-style-type: none"> <li>1. Disconnect the power supply cord, and then remove outer case.</li> <li>2. Open the door and block it open.</li> <li>3. Discharge high voltage capacitor.</li> <li>4. Isolate the switch and connect the ohmmeter to the common (COM.) and normally open (NO) terminal of the switch. The meter should indicate an open circuit with the door open and a closed circuit with the door closed. If improper operation is indicated, replace the door sensing switch.</li> <li>5. Reconnect all leads removed from components during testing.</li> <li>6. Reinstall the outer case (cabinet).</li> <li>7. Reconnect the power supply cord after the outer case is installed.</li> <li>8. Run the oven and check all functions.</li> </ol> <div style="background-color: #cccccc; padding: 5px; margin: 10px 0;"> <p> <b>CAUTION</b></p> <p><b>If the door sensing switch contacts fail in the open position and the door is closed, the cooling fan, turntable and oven light will be activated by RY1.</b></p> </div> <p><b>SECONDARY INTERLOCK RELAY (RY2)</b></p> <ol style="list-style-type: none"> <li>1. Disconnect the power supply cord, and then remove outer case.</li> <li>2. Open the door and block it open.</li> <li>3. Discharge high voltage capacitor.</li> <li>4. Disconnect two (2) wire leads from the male tab terminals of the Secondary Interlock Relay. Check the state of the relay contacts using an ohmmeter. The relay contacts should be open. If the relay contacts are closed, replace the circuit board entirely.</li> <li>5. Reconnect all leads removed from components during testing.</li> <li>6. Reinstall the outer case (cabinet).</li> <li>7. Reconnect the power supply cord after the outer case is installed.</li> <li>8. Run the oven and check all functions.</li> </ol>

# Test Procedures

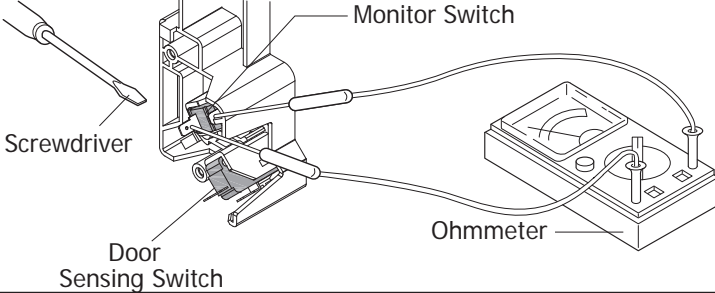
Procedure Letter	Component Test
<p><b>H</b></p>	<p><b>MONITOR SWITCH TEST</b></p> <ol style="list-style-type: none"> <li>1. Disconnect the power supply cord, and then remove outer case.</li> <li>2. Open the door and block it open.</li> <li>3. Discharge high voltage capacitor.</li> <li>4. Before performing this test, make sure that the secondary interlock switch and the primary interlock relay are operating properly, according to the Switch Test Procedure. Disconnect the wire lead from the monitor switch (COM) terminal. Check the monitor switch operation by using the ohmmeter as follows. When the door is open, the meter should indicate a closed circuit. When the monitor switch actuator is pushed by a screwdriver through the lower latch hole on the front plate of the oven cavity with the door opened (in this condition the plunger of the monitor switch is pushed in), the meter should indicate an open circuit. If improper operation is indicated, the switch may be defective. After testing the monitor switch, reconnect wire lead to monitor switch (COM) terminal and check continuity of monitor circuit.</li> <li>5. Reconnect all leads removed from components during testing.</li> <li>6. Reinstall the outer case (cabinet).</li> <li>7. Reconnect the power supply cord after the outer case is installed.</li> <li>8. Run the oven and check all functions.</li> </ol> 
<p><b>J</b></p>	<p><b>HOOD THERMAL CUT-OUT TEST</b></p> <ol style="list-style-type: none"> <li>1. Disconnect the power supply cord, and then remove outer case.</li> <li>2. Open the door and block it open.</li> <li>3. Discharge high voltage capacitor.</li> <li>4. A continuity check across the thermal cut-out terminals should indicate an open circuit unless the temperature of the thermal cut-out reaches approximately 158°F (70°C) or more. At that temperature, the contacts will close. The thermal cut-out opens automatically at approximately 104°F (40°C).</li> <li>5. Reconnect all leads removed from components during testing.</li> <li>6. Reinstall the outer case (cabinet).</li> <li>7. Reconnect the power supply cord after the outer case is installed.</li> <li>8. Run the oven and check all functions.</li> </ol>

# Test Procedures

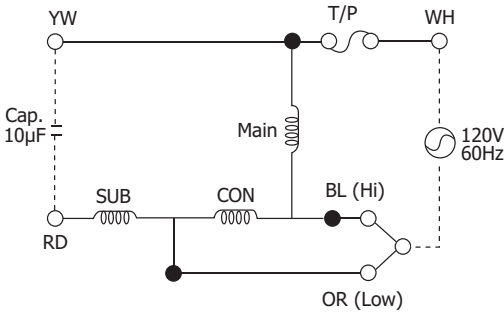
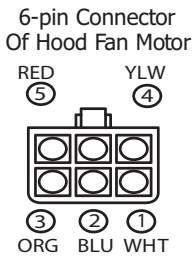
Procedure Letter	Component Test
<p><b>K</b></p>	<p><b>HOOD FAN MOTOR TEST</b></p> <ol style="list-style-type: none"> <li>1. Disconnect the power supply cord, and then remove outer case.</li> <li>2. Open the door and block it open.</li> <li>3. Discharge high voltage capacitor.</li> <li>4. If the motor does not turn, touch the FAN button once and check voltage between pins "1" and "2" (Black and Blue wires) of the 6 pin connector. If 120 Volts appear and the hood capacitor is good, replace the hood fan assembly. If 120 Volts does not appear, check the motor circuit. The resistance values of motor terminals are as follows:</li> <li>5. Reconnect all leads removed from components during testing.</li> <li>6. Reinstall the outer case (cabinet).</li> <li>7. Reconnect the power supply cord after the outer case is installed.</li> <li>8. Run the oven and check all functions.</li> </ol> <p>                     WHT (1) AND YLW (4) = 0Ω (Shorted)                      BLU (2) AND YLW (4) = 34Ω                      WHT (1) AND BLK (2) = 34Ω                      RED (5) AND WHT(1) = 77Ω                      RED (5) AND BLU (2) = 43Ω                      YLW (4) AND RED (5) = 77Ω                 </p>  
<p><b>L</b></p>	<p><b>TOUCH CONTROL PANEL ASSEMBLY TEST</b></p> <p>The touch control panel consists of circuits including semiconductors such as LSI, ICs, etc. Therefore, unlike conventional microwave ovens, proper maintenance cannot be performed with only a voltmeter and ohmmeter. In this service manual, the touch control panel assembly is divided into two units, Control Unit and Key Unit, and troubleshooting by unit replacement is described according to the symptoms indicated.</p> <p><b>Before testing,</b></p> <ol style="list-style-type: none"> <li>1. Disconnect power supply cord, and remove outer case.</li> <li>2. Open the door and block it open.</li> <li>3. Discharge high voltage capacitor.</li> <li>4. Remove two (2) screws holding the hood intake duct R to the oven cavity top plate and the base plate R. And remove the hood intake duct R.</li> <li>5. Disconnect the leads to the primary of the power transformer.</li> <li>6. Ensure that these leads remain isolated from other components and oven chassis by using insulation tape.</li> </ol> <p>Continued on next page.</p>

# Test Procedures

Procedure Letter	Component Test
	<p>KEY UNIT NOTES:</p> <ol style="list-style-type: none"> <li>1. Check key unit ribbon connection before replacement.</li> <li>2. Reconnect all leads removed from components during testing.</li> <li>3. Re-install the hood intake duct R with two (2) screws.1. Re-install the outer case (cabinet).</li> <li>4. Reconnect the power supply cord after the outer case is installed.</li> <li>5. Run the oven and check all functions.</li> </ol> <p>The following symptoms indicate a defective key unit.</p> <ol style="list-style-type: none"> <li>a) When touching the pads, a certain pad produces no signal at all.</li> <li>b) When touching a number pad, two figures or more are displayed.</li> <li>c) When touching the pads, sometimes a pad produces no signal.</li> </ol> <p>If the key unit is defective.</p> <ol style="list-style-type: none"> <li>1. Disconnect the power supply cord, and then remove outer case.</li> <li>2. Open the door and block it open.</li> <li>3. To discharge high voltage capacitor, wait for 60 seconds.</li> <li>4. Replace the key unit.</li> <li>5. Reconnect all leads removed from components during testing.</li> <li>6. Re-install the outer case (cabinet).</li> <li>7. Reconnect the power supply cord after the outer case is installed.</li> <li>8. Run the oven and check all functions.</li> </ol> <p>CONTROL UNIT</p> <p>The following symptoms indicate a defective control unit. Before replacing the control unit, perform the Key unit test (Procedure M) to determine if control unit is faulty.</p> <ol style="list-style-type: none"> <li>1. In connection with pads.             <ol style="list-style-type: none"> <li>a) When touching the pads, a certain group of pads do not produce a signal.</li> <li>b) When touching the pads, no pads produce a signal.</li> </ol> </li> <li>2. In connection with indicators.             <ol style="list-style-type: none"> <li>a) At a certain digit, all or some segments do not light up.</li> <li>b) At a certain digit, brightness is low.</li> <li>c) Only one indicator does not light.</li> <li>d) The corresponding segments of all digits do not light up; or they continue to light up.</li> <li>e) Wrong figure appears.</li> <li>f) A certain group of indicators do not light up.</li> <li>g) The figure of all digits flicker.</li> </ol> </li> <li>3. Other possible problems caused by defective control unit.             <ol style="list-style-type: none"> <li>a) Buzzer does not sound or continues to sound.</li> <li>b) Clock does not operate properly.</li> <li>c) Cooking is not possible.</li> </ol> </li> </ol> <p><b>When testing is completed,</b></p> <ol style="list-style-type: none"> <li>1. Disconnect the power supply cord.</li> <li>2. Open the door and block it open.</li> <li>3. Discharge high voltage capacitor.</li> <li>4. Reconnect all leads removed from components during testing.</li> <li>5. Re-install the hood intake duct R.</li> <li>6. Re-install the outer case (cabinet).</li> <li>7. Reconnect the power supply cord after the case is installed.</li> <li>8. Run the oven and check all functions.</li> </ol>

## Test Procedures

---

Procedure Letter	Component Test
<b>M</b>	<p><b>KEY UNIT TEST</b></p> <ol style="list-style-type: none"><li>1. Disconnect the power supply cord, and then remove outer case.</li><li>2. Open the door and block it open.</li><li>3. Discharge high voltage capacitor.</li><li>4. Remove the control panel assembly.</li><li>5. If the display fails to clear when the CANCEL pad is depressed, first verify the flat ribbon cable is making good contact, verify that the door sensing switch (stop switch) operates properly; that is the contacts are closed when the door is closed and open when the door is open. If the door sensing switch (stop switch) is good, disconnect the flat ribbon cable that connects the key unit to the control unit and make sure the door sensing switch is closed (either close the door or short the door sensing switch connector). Use the Key unit matrix indicated on the control panel schematic and place a jumper wire between the pins that correspond to the CANCEL pad making momentary contact. If the control unit responds by clearing with a beep the key unit is faulty and must be replaced. If the control unit does not respond, it is faulty and must be replaced. If a specific pad does not respond, the above method may be used (after clearing the control unit) to determine if the control unit or key pad is at fault.</li><li>5. Reconnect all leads removed from components during testing.</li><li>6. Re-install the outer case (cabinet).</li><li>7. Reconnect the power supply cord.</li><li>8. Run the oven and check all functions.</li></ol>

# Test Procedures

---

Procedure Letter	Component Test								
O	<p><b>DEFROST CENTER TEST</b></p> <ol style="list-style-type: none"> <li>1. Open the door.</li> <li>2. Place one cup of water in the center of the turntable tray in the oven cavity.</li> <li>3. Close the door.</li> <li>4. Touch the “DEFROST” pad once.</li> <li>5. Touch the “ START “ button.</li> <li>6. Touch the number pad “5”.</li> <li>7. Touch the “ START “ button.</li> <li>8. The oven is in Defrost Center cooking condition.</li> </ol>								
Q	<p><b>NOISE FILTER TEST</b></p> <ol style="list-style-type: none"> <li>1. Disconnect the power supply cord, and then remove outer case.</li> <li>2. Open the door and block it open.</li> <li>3. Discharge high voltage capacitor.</li> <li>4. Disconnect the leads to the primary of the power transformer.</li> <li>5. Using an ohm-meter, check between the terminals as described in the following table:</li> </ol> <table border="1" data-bbox="344 1249 1082 1429"> <thead> <tr> <th>Measuring Point</th> <th>Indication Of Ohm-meter</th> </tr> </thead> <tbody> <tr> <td>Between N and H</td> <td>Open Circuit</td> </tr> <tr> <td>Between terminal N and LOAD</td> <td>Short Circuit</td> </tr> <tr> <td>Between terminal H and LOAD</td> <td>Short Circuit</td> </tr> </tbody> </table> <p>If incorrect readings are obtained, replace the noise filter.</p> <ol style="list-style-type: none"> <li>6. Reconnect all leads removed from components during testing.</li> <li>7. Re-install the outer case (cabinet).</li> <li>8. Reconnect the power supply cord after the outer case is installed.</li> <li>9. Run the oven and check all functions.</li> </ol>	Measuring Point	Indication Of Ohm-meter	Between N and H	Open Circuit	Between terminal N and LOAD	Short Circuit	Between terminal H and LOAD	Short Circuit
Measuring Point	Indication Of Ohm-meter								
Between N and H	Open Circuit								
Between terminal N and LOAD	Short Circuit								
Between terminal H and LOAD	Short Circuit								

## ATTACHED FILES LIST

**1. Exploded View**

**2. Spare Parts List**

**3. Wiring Diagram**

\* Note: The manual may update without prior notice. Please download the latest version on website: <https://tsp.midea.com>.