



USER MANUAL

PASTA COOKER

KoolMore Commercial Pasta Cooker

Models: KM-PC6-NG | KM-PC12-NG

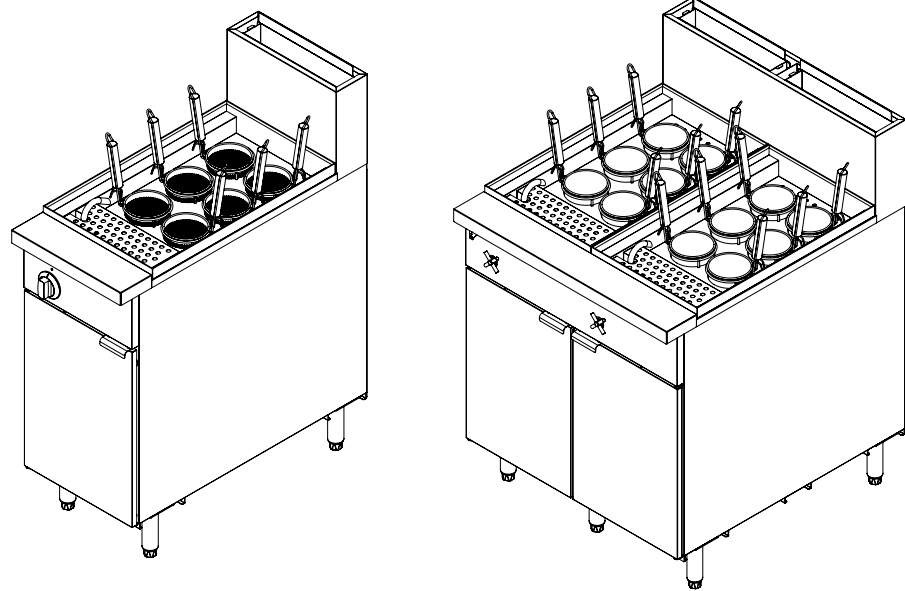

Before using, please read the operating instructions carefully to ensure proper application and achieve satisfactory results.

For any service-related issues, please contact us:



718-576-6342



support@koolmore.com

***Stay informed with the latest information
for your KoolMore Appliance.***

**If you need any assistance or have questions, our customer
support team is here to help.**

Contents

Safety	4
Installation	5
Operation	8
Maintenance	10
Troubleshooting	12
Warranty	13

SAFETY

Before attempting to operate your unit, read the instructions in this manual thoroughly.

WARNING boxes contain information about actions or conditions that may cause or result in a malfunction of your system.

The gas noodle cooker is designed for boiling pasta, noodles, vegetable etc. This cooker uses a millivolt temperature control circuit, which requires no external power.

This model adopts an open-tank design with no tubes, which makes cleaning the water tank quick and easy.

The noodle cooker requires installation of legs or optional casters at point of use. All noodle cookers are shipped with a package of standard accessories. Each noodle cooker is adjusted, tested, and inspected at the factory before crating for shipment.

Water tanks are constructed of welded, heavy-gauge stainless steel. Heat is supplied by two stainless steel burners, which are installed under the tank bottom.

A drain is installed at the right hand of the water tank, with a front-controlled manual ball valve.

Each noodle cooker is equipped with a thermostat for precise temperature control. The thermostat is located at the front part of the water tank for rapid response to changes in loads and to provide the most accurate temperature measurement.

A high temperature thermostat (hi-limit) shuts off gas to the burner assembly if the controlling thermostat fails.

If unit arrives damaged:

This unit was carefully inspected and packed before leaving the factory. The transportation company assumes full responsibility for safe delivery upon acceptance of the equipment for transport.

What to do if your equipment arrives damaged:

1. File a claim for damages immediately, regardless of the extent of damages
2. Inspect for and record all visible loss or damage, and ensure that this information is noted on the freight bill or express receipt and is signed by the person making the delivery.

INSTALLATION

PROPER INSTALLATION

Proper installation in accordance with the instructions that follow is essential for efficient, trouble-free operation of your noodle cooker. Any unauthorized alterations made to this equipment will void the warranty.

Upon arrival, inspect the cooker carefully for visible or concealed damage.

Clearance and Ventilation:

The cooker(s) must be installed with a 6" clearance at both sides and back when adjacent to combustible construction; no clearance is required when adjacent to noncombustible construction. A minimum of 24" clearance should be provided at the front of the cooker.

One of the most important considerations for efficient cooker operation is ventilation. Make sure the cooker is installed to efficiently remove combustion by-products and that the kitchen ventilation system does not produce drafts that interfere with proper burner operation. The cooker flue opening must not be placed close to the intake of the exhaust fan, and the cooker must never have its flue extended in a "chimney" fashion. An extended flue will change the combustion characteristics of the cooker, causing longer recovery time and frequently causing delayed ignition. To provide the airflow necessary for good combustion and burner operation, the areas surrounding the noodle cooker front, sides, and rear must be kept clear and unobstructed.

The cooker must be installed in an area with an adequate air supply and adequate ventilation. Adequate distances must be maintained from the flue outlet of the cooker to the lower edge of the ventilation filter bank.

National Code Requirements:

The type of gas for which the cooker is equipped is marked on the data plate attached to the inside of the cooker door. Connect a cooker marked "NAT" only to natural gas, and those marked "PRO" only to propane gas.

When installing this equipment in the United States, the installation must conform to the latest edition of the National Fuel Gas Code, ANSI Z223.1. In Canada, installation must conform to the latest edition of Standard CAN-/ GCA-B149.1 or .2, "Installation Codes for Gas Burning Appliances & Equipment." In addition to the applicable national code or standard, installation must also be in accordance with any local codes for the area in which the equipment is installed.

Installation shall be made with a gas connector that complies with national and local codes. In the United States, the applicable code is ANSI Z21.69 with Addenda, "Standard for Connectors for Movable Gas Appliances." Quick-disconnect devices, if used, shall likewise comply with national and local

codes. In the United States, the code is ANSI Z21.41, "Standard for Quick-Disconnect Devices for Use with Gas Fuel."

Model	KM-PC6-NG	KM-PC12-NG
Dimension (in)	15.75 x 33.78 x 47.24	31.5 x 33.78 x 47.24
L.P.G Orifice (No./in)	50# / 0.07in*2	50# / 0.07in*4
NAT Orifice (No./in)	35# / 0.11in*2	35# / 0.11in*4
Total Rate (BTU/H)	70,000	70000 *2
LP.IN. W.C	10" W.C	10" W.C
NAT.IN. W.C	4" W.C	4" W.C
Gallon	11	11+11

Pre-connection Preparations:

After the cooker has been positioned under the cook station exhaust hood, ensure the following has been accomplished:

- Adequate means must be provided to limit the movement of cookers without depending upon the gas line connections. If a flexible gas hose is used, a restraining cable must be connected at all times when the cooker is in use. The restraining cable and installation instructions are packed with the flexible hose in the accessories box that was shipped with your unit.
- These cookers must be stabilized by installing restraining chains on noodle cookers equipped with casters or anchor straps on cookers equipped with legs. Follow the instructions shipped with the casters/legs to properly install the chains or straps.
- Level cookers equipped with legs by extending the adjustable portion of the leg out approximately 1 inch, and then further adjust the legs, ensuring the cooker is level and at the proper height under the exhaust hood. For cookers equipped with casters, the floor where the cooker is to be installed must be level.
- Refer to the data plate on the inside of the cooker door to verify that the cooker is configured for the proper type of gas before connecting the noodle cooker quick-disconnect device or piping from the gas supply line.
- Verify that the minimum and maximum gas supply pressures for the type of gas to be used are in accordance with the table above.

Connect to the Gas Line:

The size of the gas line used for installation is very important. If the line is too small, the gas pressure at the burner manifold will be low. This may cause pilot outage, slow recovery, and delayed ignition. The incoming gas supply line should be a minimum of 1½" in diameter. All single cookers using natural gas require a ¾" or 1/2" connection. For cookers using LP gas, one pipe size smaller may be used. If in doubt about the correct pipe size, consult the local gas company.

1. Before connecting new pipe to your unit, the pipe must be thoroughly blown out to remove any foreign particles. If these foreign particles get into the burner and controls, they will cause improper and sometimes dangerous operation.
2. Connect the quick-disconnect hose to the noodle cooker quick-disconnect fitting at the rear of the cooker and to the building gas line.

NOTE: Some noodle cookers are configured for a rigid connection to the gas supply line. These units are connected directly to the gas supply line. When using thread compound, use very small amounts

on male threads only. Use a pipe thread compound that is not affected by the chemical action of LP gases (Loctite™ PST56765 Sealant is one such compound).

3. DO NOT apply compound to the first two threads. This will ensure that the burner orifices and control valve do not become clogged.
4. Open the gas supply to the cooker and check all piping, fittings, and gas connections for leaks. A soap and water solution should be used for this purpose.

NOTE: The cooker must be disconnected from the gas supply piping during any pressure testing of the gas supply piping pressures equal to or greater than ½ psig (3.45 kPa or 13.84 in. W.C.).

5. Close the cooker drain valve and fill the water tank with water or boil-out solution to the bottom WATER LEVEL line at the rear of the water tank. Light the cooker and perform the boil-out procedures that are described in the “Start-Up Procedure” and “Boiling Out the Water Tank” topics.
6. It is suggested that the burner manifold pressure be checked at this time by the local gas company or an authorized service agent. Refer to “Check Burner Manifold Pressure” in this manual for the proper procedure.

Water and Gas Connection:

This model is specially designed to boil pasta and noodles. Water should be connected to this unit. The black pipe is for gas connection. The middle pipe is for wastewater drainage. Please make sure you have the right connection. A wrong connection would damage the valve and cause gas leakage.

OPERATION

Operating the Gas Valve:

The knob on the gas valve is placed in the PILOT or ON position by rotating it counter-clockwise. To return the knob to the OFF position, the knob must be depressed slightly to disengage its stop tab, then rotated clockwise.

Lighting the Pilot and Burner:

1. Open the door.
2. Turn the thermostat OFF (see figure below, view A). The thermostat is located behind the door.
3. Push the gas control valve knob and turn it to OFF. Wait 5 minutes for unburned gas to vent.
4. Push and turn the gas control valve knob to the "L" in PILOT (see figure below, view B).
5. While still holding the knob in, light the pilot with a lit flame. Continue to depress the knob until the pilot remains lit when the knob is released. If the pilot does not remain lit, repeat steps 3 through 5.
6. If the pilot fails to remain lit, wait five minutes before attempting to re-light.
7. Depress and turn the gas control knob to ON (see figure below, view C).
8. If the gas supply is interrupted, repeat steps 2 through 6.

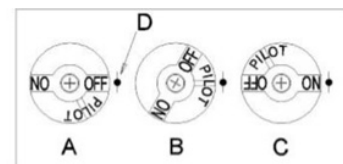

A Gas Valve Knob, View A
B Gas Valve Knob, View B
C Gas Valve Knob, View C
D Indicator Point, All Views

Filling With Water:

Turn on the faucet to fill the water tank with water. Do not exceed the max water-level.

Thermostat Operation:

Note: The boiling point of water might vary at different altitudes.

The thermostat is connected to a graduated knob located inside the cooker door. Rotating the knob clockwise to the desired cooking temperature (set-point) directly adjusts the thermostat to that temperature. The thermostat controls the water tank temperature by regulating the gas supply to the burner via the gas valve.

The thermostat is in the full OFF position when the word OFF is at the top of the knob. A "click" will be heard when the knob is rotated from the OFF position to a temperature or when it is rotated back to

the OFF position.

Draining:

Rotate the gas valve knob to the PILOT or OFF position.

Open the drain valve slowly.

Clean all food particles and residual water from the water tank before refilling.

Close the drain valve and refill the water tank with clean water.

MAINTENANCE

Daily Checks and Services:

Inspect Cooker and Accessories for Damage:

1. Look for loose wires, leaks, foreign material in the water tank or inside the cabinet, and any other indications that the noodle cooker and accessories are not ready and safe for operation.
2. Inspect the burner deflectors to verify that each is positioned directly above its orifice, and that the flame ignites approximately 2½ inches (60mm) above the orifice. The flame should strike the center of the deflector and be a rich blue color.

Clean Cooker Cabinet Inside and Out:

1. Clean inside the cooker cabinet with a dry, clean cloth. Wipe all accessible metal surfaces and components to remove accumulations of dust.
2. Clean the outside of the cooker cabinet with a clean, damp cloth soaked with dishwashing detergent, removing dust and lint from the cooker cabinet.

Quarterly Checks and Services:

Drain and Clean Water Tank:

During normal usage of your cooker, a deposit of water scale will gradually form on the inside of the tank. This deposit must be periodically removed to maintain your cooker's efficiency. Follow the procedures for draining the water tank, then follow the "Boiling Out the Water Tank" procedures.

Clean Detachable Parts and Accessories:

Wipe all detachable parts and accessories with a clean cloth dampened with a detergent solution. Rinse and thoroughly dry each part.

Semi-annual Checks and Services:

Check Burner Manifold Pressure:

1. Ensure that the gas valve knob is in the OFF position.
2. Remove the pressure tap plug from the burner manifold.
3. Insert the fitting for a manometer or pressure gauge into the pressure tap hole.
4. Place the gas valve in the PILOT position and light the pilot. When the pilot lights and continues to burn, increase the setting on the thermostat knob until the burner lights. Compare the manometer or gauge reading to the appropriate table below.
5. If the burner manifold pressure does not meet the specifications in the tables in Step 4, unscrew the slotted cap from the top of the gas valve regulator (adjacent to the gas valve vent tube) and turn the adjusting screw to obtain the correct pressure. Turn the screw clockwise to increase pres-

sure, counter-clockwise to decrease pressure.

6. After adjusting the manifold pressure to the correct value, reinstall the regulator cap and turn the gas valve knob to the OFF position.
7. Remove the manometer or pressure gauge fitting from the pressure tap hole and reinstall the pipe plug.
8. Place the gas valve in the PILOT position and check for gas leaks. If no leaks are found, re-light the pilot and return the unit to operation.

TROUBLESHOOTING

Operator Troubleshooting:

The tables that follow provide operators with a list of possible malfunctions, the probable causes of the malfunctions, and the corrective actions to take to correct the problem. In some cases, the operator may not be able to correct the problem, but will at least be able to accurately diagnose the problem, assisting a qualified service technician in restoring the equipment to full operation in the shortest possible time.

Warning: This task should be performed by qualified service personnel only.

Warning: The noodle/pasta cooker must be filled with water during this procedure.

Problem	Probable Cause	Corrective Action
Burner does not light at all	- Pilot is not lit	- Light the pilot.
	- Loose, dirty, or corroded terminals on the gas valve	- Clean and tighten terminals on the gas valve.
	- Loose, dirty, or corroded terminals on the thermostat	- Clean and tighten terminals on the thermostat.
Burner does not light all the way around	- One or more burner orifices are clogged	- Turn the gas valve knob to the OFF position. Use a thin wire to clear obstruction from burner orifices.
	- Blocked flue	- Clear blockage from the flue.
Burner experiences delayed ignition	- Too little make-up air in the kitchen	- Adjust the kitchen ventilation system to increase make-up air.
Flame rolling out from under noodle cooker	- Flue obstructed	- Remove obstruction from the flue.
Pilot repeatedly goes out	- Clogged pilot orifice	- Use a small wire to clear obstruction from the pilot orifice.
	- Pilot flame blowing away from the pilot generator (excessive draft in the kitchen)	- Eliminate the draft in the kitchen.
	- Pilot generator not inserted fully into the pilot burner	- Reinsert the pilot generator into the pilot burner until the flame surrounds the tip.
	- Corroded connection where the pilot generator connects to the gas valve	- Clean the pilot generator connection at the gas valve.
	- If all of the above causes have been ruled out, the probable causes are low pilot flame, pilot generator low millivolt output, high resistance in hi-limit thermostat contacts, or a defective pilot magnet in the gas valve	- Call for service.



WARRANTY

LIMITED WARRANTY

Koolmore Supply, Inc. extends a limited warranty to the original purchaser, guaranteeing that this Koolmore product is free from manufacturing defects in material or workmanship for one year from the date of purchase.

Should you discover any such defect within the warranty period, Koolmore Supply, Inc., reserves the right to repair or replace the product without charge, or to cover the cost of replacement parts and repair labor needed to correct defects present at the time of purchase or resulting from regular usage, when the appliance has been installed, operated, and maintained as per the instructions provided.

At its sole discretion, Koolmore Supply Inc. may decide to replace the product. In such an event, your replacement appliance will carry the warranty for the remaining term of the original unit's warranty period.

This warranty is valid exclusively to the original purchaser of the product and only applicable within the United States. The warranty commences from the date of original consumer purchase. Proof of the original purchase date will be required to obtain service under this warranty.

Under this limited warranty, your sole and exclusive remedy will be product repair, as outlined above. All services must be provided by a Koolmore-designated service company.

To claim warranty or request repair service:

Email support@koolmore.com. Please include your name, address, phone number, warranty repair request, and a copy of your proof of purchase receipt. Alternatively, visit koolmore.com and use the contact us page. A Koolmore customer service representative will promptly arrange service for your appliance.

We thank you for choosing Koolmore.

WARRANTY EXCLUSIONS

This limited warranty will not cover:

1. Failure of the product to perform during power failures or interruptions, or due to inadequate electrical service.
2. Damage incurred during transportation or handling.
3. Damage caused by accidents, vermin, lightning, winds, fire, floods, or acts of God.
4. Damage resulting from accidents, alterations, misuse, abuse, improper installation, repair, or maintenance. This includes using any external device that alters or converts the voltage or frequency of electricity.
5. Unauthorized product modifications, repairs by unauthorized centers, or use of non-approved replacement parts.
6. Abnormal cleaning and maintenance not aligned with the user's manual.
7. Use of incompatible accessories or components.
8. Any costs associated with repairs or replacements under these excluded circumstances shall be the responsibility of the consumer.

