

# Setup and Operation

## KM-PHWS-ST16-W, KM-PHWS-ST26-W, KM-PHWS-ST26

**Tools Required:** Phillips head screwdriver or drill

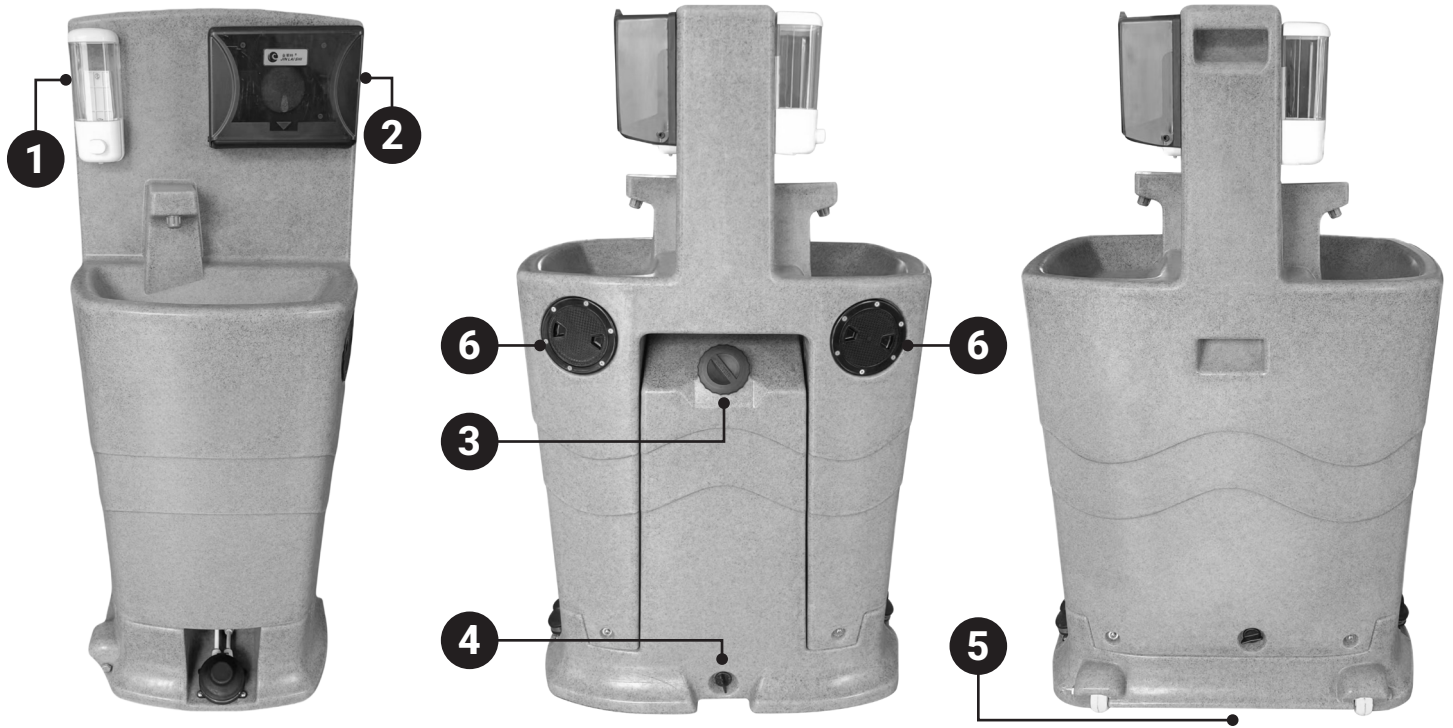

### 1. Mounting the soap dispenser:

Mount the soap dispenser as close to the top-left side of the unit as possible using the included screws.

### 2. Mounting the paper towel dispenser:

Mount the paper towel dispenser as close to the top-right side of the unit as possible using the included screws.

### 3. Fill with Fresh Water:

Unscrew the cap located to the right of the basin and fill with clean water. Secure the cap after filling.

### 4. Drain Fresh Water:

Unscrew the cap and carefully tilt the unit to allow the water to drain out.

### 5. Drain Waste Water:

Unscrew the drain cap located at the bottom of the unit and allow the wastewater to flow out completely.

### 6. Check Waste Water Level:

Unscrew the cap near the basin to check the wastewater tank level.



# WARRANTY

## LIMITED WARRANTY

---

KoolMore Supply Inc. extends a limited warranty to the original purchaser, guaranteeing that this KoolMore product is free from manufacturing defects in material or workmanship for one year from the date of purchase.

Should you discover any such defect within the warranty period, KoolMore Supply Inc. reserves the right to repair or replace the product without charge, or to cover the cost of replacement parts and repair labor needed to correct defects present at the time of purchase or resulting from regular usage, when the appliance has been installed, operated, and maintained as per the instructions provided.

At its sole discretion, KoolMore Supply Inc. may decide to replace the product. In such an event, your replacement appliance will carry the warranty for the remaining term of the original unit's warranty period.

This warranty is valid exclusively to the original purchaser of the product and only applicable within the United States. The warranty commences from the date of original consumer purchase. Proof of the original purchase date will be required to obtain service under this warranty.

Under this limited warranty, your sole and exclusive remedy will be product repair, as outlined above. All services must be provided by a KoolMore designated service company.

KoolMore shall not be responsible or liable for any loss, spoilage, or damage to food, beverages, pharmaceuticals, medical supplies, or any other contents stored in the unit resulting from failure, malfunction, defects, improper installation, improper use, power interruption, or any other cause. Any such losses are expressly excluded from coverage under this warranty.

To claim warranty or request repair service:

Email [support@koolmore.com](mailto:support@koolmore.com). Please include your name, address, phone number, warranty repair request, and a copy of your proof of purchase receipt. Alternatively, visit [koolmore.com](http://koolmore.com) and use the Contact Us page. A KoolMore customer service representative will promptly arrange service for your appliance.

We thank you for choosing KoolMore.

## WARRANTY EXCLUSIONS

---

This limited warranty will not cover:

1. Failure of the product to perform during power failures or interruptions, or due to inadequate electrical service.
2. Damage incurred during transportation or handling.
3. Damage caused by accidents, vermin, lightning, winds, fire, floods, or acts of God.
4. Damage resulting from accidents, alterations, misuse, abuse, improper installation, repair, or maintenance. This includes using any external device that alters or converts the voltage or frequency of electricity.
5. Unauthorized product modifications, repairs by unauthorized centers, or use of non-approved replacement parts.
6. Abnormal cleaning and maintenance not aligned with the user's manual.
7. Use of incompatible accessories or components.
8. Any costs associated with repairs or replacements under these excluded circumstances shall be the responsibility of the consumer.