



SPEC SHEET

60 in. Commercial 2-Door Refrigerated Salad and Sandwich Prep Table, 16 Pan Capacity and 18.4 Cu. Ft. of Storage

Model: - KM-PTR60-2D

FEATURES

- **18.4 Cu. Ft. Refrigerated Base:** Includes an adjustable 88-lb shelf for storing chilled ingredients.
- **16-Pan Top:** Accommodates 1/6 GN pans, with plastic pans included.
- **Consistent Cooling:** Maintains a consistent temperature range of 33°F to 40°F.
- **Digital Temperature Controls:** Bright LED display for quick monitoring and adjustments.
- **Removable Cutting Board:** Made from high-density polyethylene, spacious 10.31 inch depth.
- **Insulated Pan Cover:** Helps maintain cold temperatures and reduce food waste.
- **Stainless-Steel Construction:** Strong 430 exterior and 201 interior for corrosion resistance.
- **Auto Defrost & Steady Airflow:** Ensures consistent cooling with low upkeep.
- **Four Casters for Easy Mobility:** Two locking casters for secure placement.
- **ETL Certified + 1-Year Warranty:** Meets safety standards and includes full parts-and-labor coverage.



CLOSE UP IMAGES



Technical Specs

Dimensions & Weight

Length	60.2 in.
Width	34.0 in.
Height	45.1 in.
Weight	352 lbs
Interior Depth	19.8 in.
Interior Width	56.5 in.
Interior Height	23.5 in.
Depth Excluding Handles	34 in.
Depth Including Handles	34 in.
Depth Less Door	34 in.
Depth With Door Open 90°	57.5 in.
Height to Top of Door Hinge	32.4 in.
Minimum Back Air Clearance	2 in.
Minimum Side Air Clearance	2 in.

Electric & Certifications

Certifications	ETL Listed for Safety and Sanitation
Amps	5.4
Hertz	60
Phase	1
Voltage	115
Wattage	540
Plug Type	NEMA 5-15P
Power Cord Length	98.4 in.
Electrical Installation Type	Plug-in

Capacity

Gross Cubic Feet	18.4
Net Cubic Feet	16.6
Number of Shelves	3
Individual Shelf Capacity	88 lbs.
Temperature Range	33–40
Ambient Temperature Range	90 F

Features & Materials

Handle Type	Recessed
Door Style	Swing
Defrost Type	Automatic
Cooling Unit Type	Automatic
Refrigerant Type	R-290
Horsepower	0.5
Number of Doors	2
Interior Lights	No
Control Type	Digital
Color / Finish	Stainless-Steel
Shelf Material Type	Polymer Coated Steel
Shelves Adjustable	Yes
Interior Material	201 Stainless-Steel
Exterior Material	430 Stainless-Steel
Casters	4
Pans Included	Yes
Pan Capacity	16

Plan View

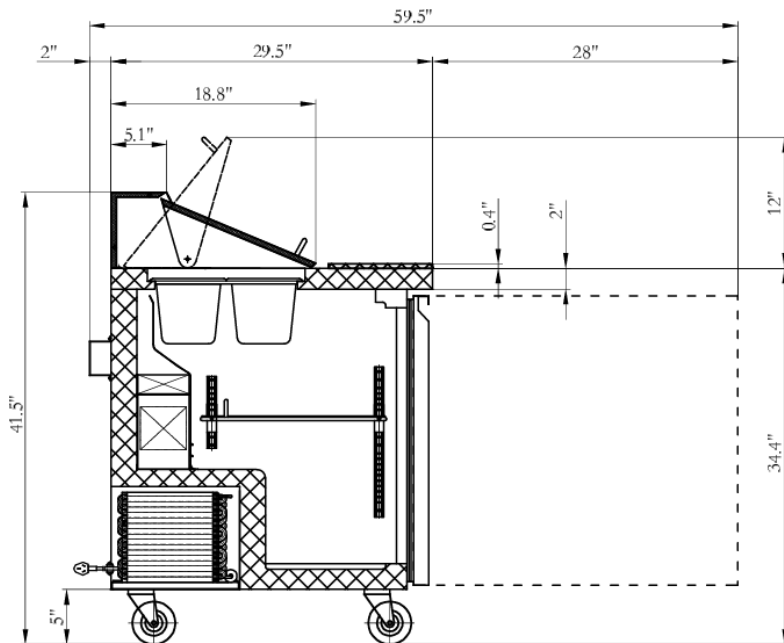
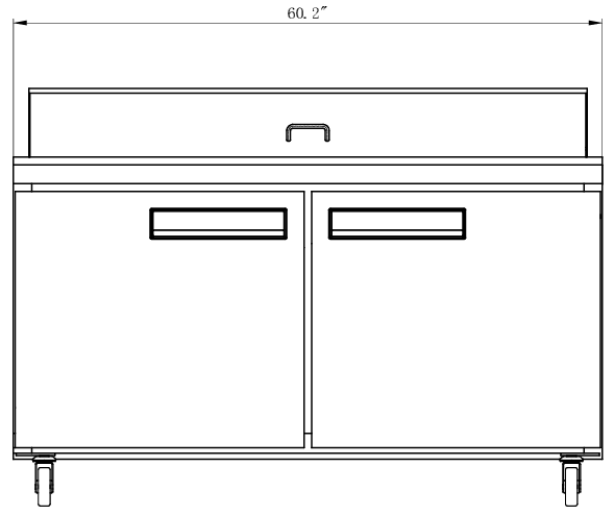
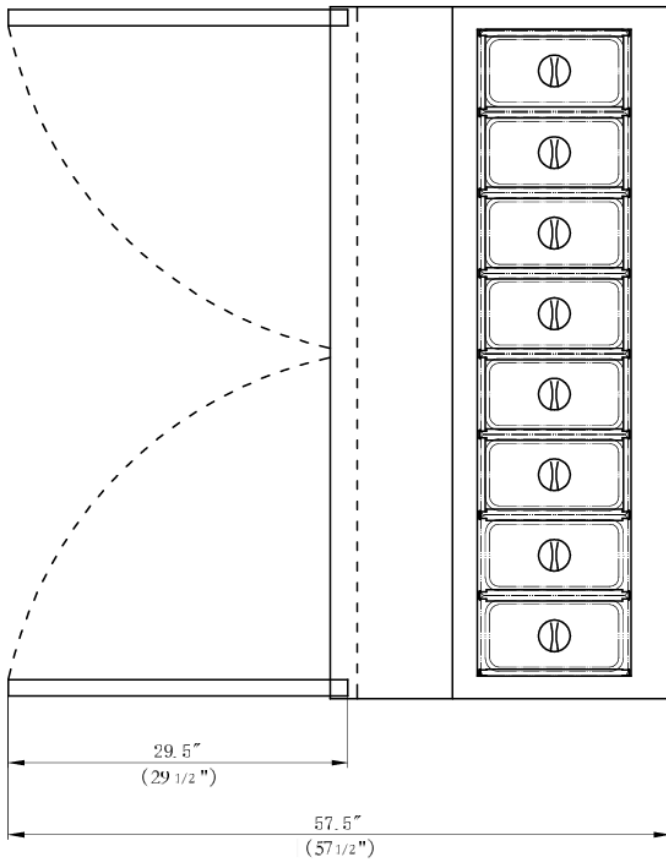

718-576-6342
 info@koolmore.com