



SPEC SHEET

KoolMore 48 in. Commercial Refrigerated Prep Station Cold Table, Stainless-Steel Refrigerator with 9 Pan Storage with Cover and Two Adjustable Shelves

SKU: KM-RBT-48C

FEATURES

- Commercial Cold Table Refrigerator
- Stainless-Steel Refrigeration Unit
- Automatic Defrost
- Digital Temperature Control
- 1-Year Parts and Labor; 5-Year Compressor Warranty
- Voltage: 115V/60Hz
- ETL Certified for Safety and Sanitation



CLOSE UP IMAGES



TECHNICAL SPECS

Dimensions

Depth	46.9
Width	29.5
Height	35.2
Interior Depth	19.8
Interior Width	43
Interior Height	23.5
Shelf Width	20.8
Shelf Depth	17.1
Depth Including Handles	29.5
Depth Excluding Handles	29.5
Depth Less Door	50.8
Depth With Door Open 90 Degrees	50.8
Power Cord Length	98.5

Capacity

Weight	275
Gross Cubic Feet	14
Net Capacity Cu. Ft.	11.1
Individual Shelf Capacity	88 lbs.
Pan Capacity	9

Features & Material

Door Style	Swing
Number Of Doors	2
Number Of Shelves	2
Defrost Type	Automatic
Refrigerant Type	R290
Temperature Control Type	Digital
Ambient Temperature Range	90 F
Temperature Range	33-40 F
Casters	4
Light Type	NA
Shelf Material Type	Plastic Coated
Interior Material	SS 201
Exterior Material	SS 430

Electric Data & Certifications

Amps	4.9
Phase	1
Plug Type	NEMA 5-15P
Voltage	115
Hertz	60
Wattage	504
Horsepower	0.5
Certifications	ETL Listed for Safety and Sanitation

Plan View

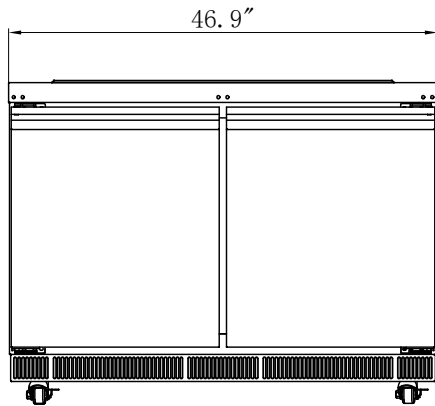

ELEVATION

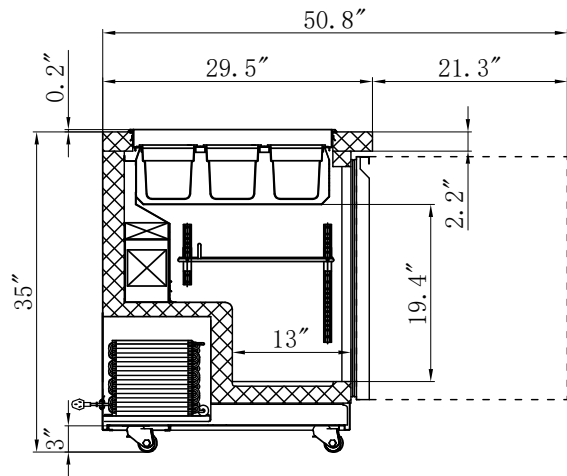

SECTION VIEW

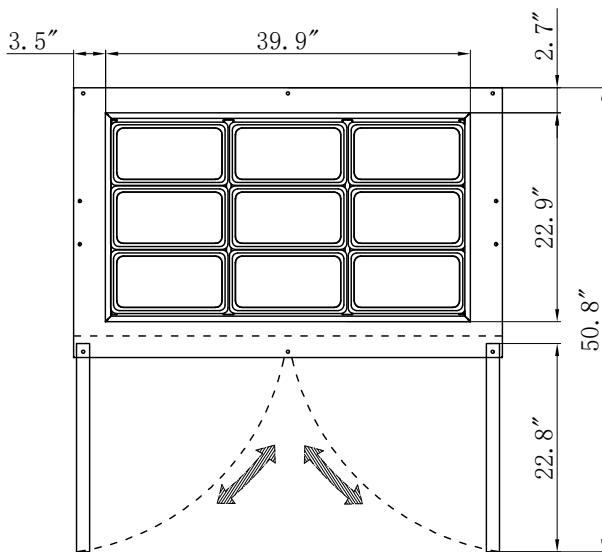

PLAN

CERTIFICATIONS



Intertek



Intertek



706 Eastern Parkway STE 1G, Brooklyn NY 11213
718-576-6342
info@koolmore.com