



# SPEC SHEET

## KoolMore 72 in. Commercial Refrigerated Prep Station Cold Table, Stainless-Steel Refrigerator with 15 Pan Storage with Cover and Two Adjustable Shelves

SKU: KM-RBT-72C

### FEATURES

- Commercial Cold Table Refrigerator
- Stainless-Steel Refrigeration Unit
- Automatic Defrost
- Digital Temperature Control
- 1-Year Parts and Labor; 5-Year Compressor Warranty
- Voltage: 115V/60Hz
- ETL Certified for Safety and Sanitation



### CLOSE UP IMAGES



# TECHNICAL SPECS

## Dimensions

Depth	70.6
Width	29.5
Height	35.2
Interior Depth	19.8
Interior Width	66.6
Interior Height	23.5
Shelf Width	21.6
Shelf Depth	17.1
Depth Including Handles	29.5
Depth Excluding Handles	29.5
Depth Less Door	50.8
Depth With Door Open 90 Degrees	50.8
Power Cord Length	98.5

## Capacity

Weight	374
Gross Cubic Feet	21
Net Capacity Cu. Ft.	17.4
Individual Shelf Capacity	88 lbs.
Pan Capacity	15

## Features & Material

Door Style	Swing
Number Of Doors	3
Number Of Shelves	3
Defrost Type	Automatic
Refrigerant Type	R290
Temperature Control Type	Digital
Ambient Temperature Range	90 F
Temperature Range	33-40 F
Casters	4
Light Type	NA
Shelf Material Type	Plastic Coated
Interior Material	SS 201
Exterior Material	SS 430

## Electric Data & Certifications

Amps	6.7
Phase	1
Plug Type	NEMA 5-15P
Voltage	115
Hertz	60
Wattage	700
Horsepower	0.7
Certifications	ETL Listed for Safety and Sanitation

# Plan View

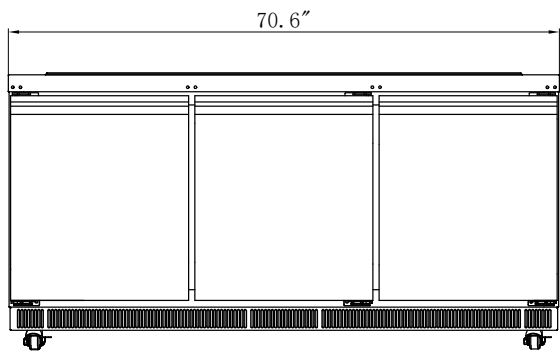

ELEVATION

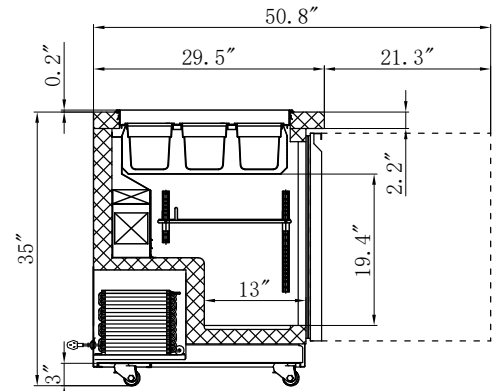

SECTION VIEW

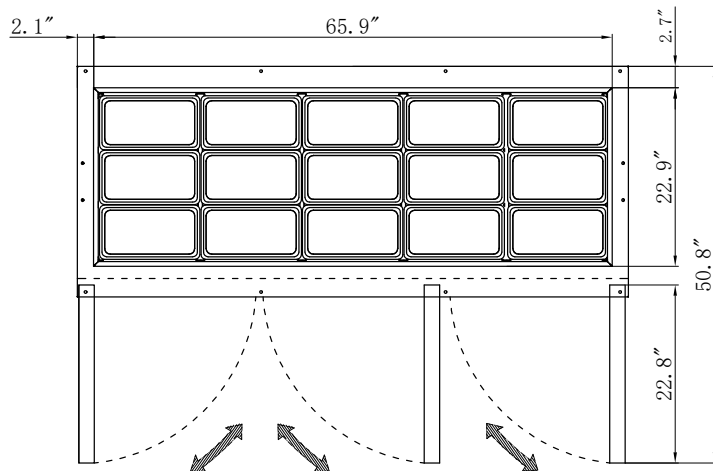

PLAN

## CERTIFICATIONS



706 Eastern Parkway STE 1G, Brooklyn NY 11213  
718-576-6342  
info@koolmore.com