

Food Table Refrigerator

Cold Food Table Refrigerator

Models:

KM-RBT-36 | KM-RBT-48 | KM-RBT-60 | KM-RBT-72

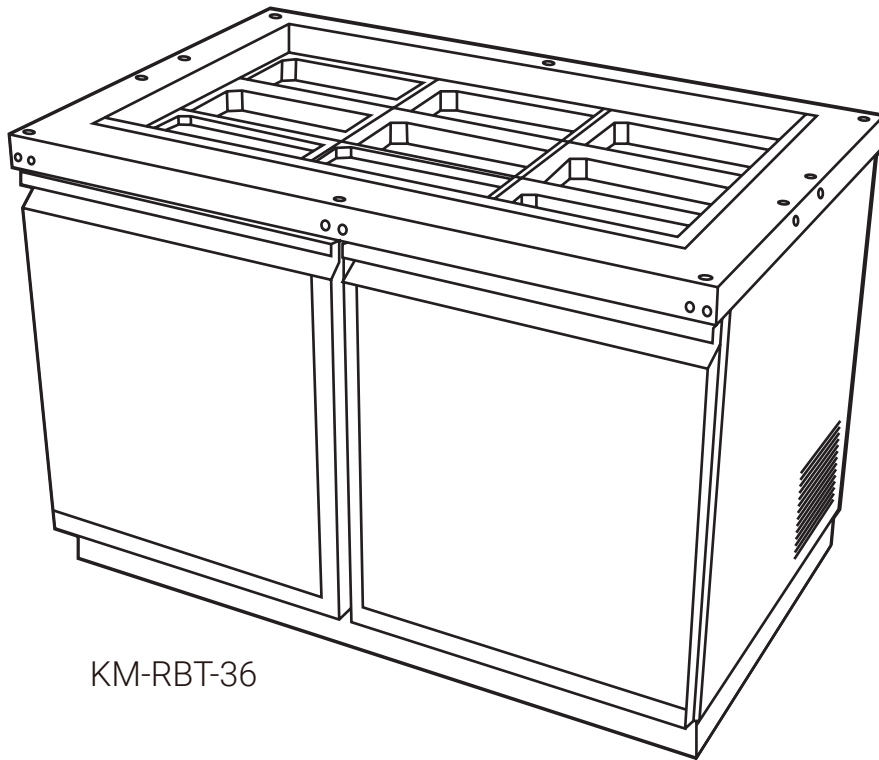

KM-RBT-36

Before using, please read the operating instructions carefully to ensure proper application and achieve satisfactory results.

For any service-related issues, please contact us:



718-576-6342



support@koolmore.com

Stay informed with the latest information for your KoolMore Appliance.

Scan the QR code above to access the most recent user manual on our website, which is constantly being updated and improved.

If you need any assistance or have questions, our customer support team is here to help.

SAFETY PRECAUTIONS

Your safety is our top priority. Before installing and using this equipment, please read and follow these important warnings and guidelines:

- 1. Make sure there is enough space between the wall, cabinet, and ceiling. Don't completely seal off the back of the cabinet; provide an air vent to the outside. Caution: Maintain a distance of more than 8 inches from the cabinet to the wall.**
- 2. Remove all external packaging materials to prevent overheating and the risk of fire.**
- 3. Do not store flammable or volatile chemicals, as they may lead to explosions.**
- 4. Use individual single-phase outlets, ensuring a reliable connection to a grounding wire. Caution: Do not connect the grounding wire to a water or gas pipe.**
- 5. During transportation, avoid harsh collisions or excessive vibrations; the cabinet should not be inclined beyond 45 degrees.**
- 6. Consult the Troubleshooting guide if the unit experiences issues. Do not attempt to resolve problems yourself; seek assistance from a certified technician.**
- 7. DANGER: Risk of fire or explosion due to flammable refrigerant. Do not use mechanical devices to defrost the refrigerator, and do not puncture the refrigerant tubing.**
- 8. DANGER: Risk of fire or explosion due to flammable refrigerant. Repairs should only be carried out by trained service personnel. Do not puncture the refrigerant tubing.**
- 9. CAUTION: Risk of fire or explosion due to flammable refrigerant. Refer to the repair manual or owner's guide before attempting to service this product. Adhere to all safety precautions.**
- 10. CAUTION: Risk of fire or explosion due to flammable refrigerant. Dispose of the product properly in accordance with federal or local regulations.**
- 11. CAUTION: Risk of fire or explosion due to puncturing of refrigerant tubing. Follow handling instructions carefully when dealing with flammable refrigerant.**
- 12. CAUTION: Keep all ventilation openings in the appliance enclosure or building structure free from obstructions.**
- 13. CAUTION: Servicing should be performed by factory-authorized service personnel to minimize the risk of ignition caused by incorrect parts or improper service.**

ATTENTION

It's crucial to adhere to the following safety guidelines. Neglecting these instructions may result in severe injury or damage to the appliance.

- Ensure the appliance is connected to a dedicated outlet to prevent electrical overload and potential fire hazards.**
- Avoid the use of extension cords.**
- When needing to move the appliance, do not place your hands underneath it.**
- If the appliance will not be in use for an extended duration, disconnect it from the power source.**

- After unplugging the appliance, allow a minimum of 10 minutes before reconnecting it to prevent compressor damage.

UNPLUGGING PROCEDURES

- Always ensure your hands are dry when handling the power cord to prevent electrical shocks.
- Prior to any maintenance or cleaning activities, disconnect the appliance from the power source.

GROUNDING INSTRUCTIONS

For safety reasons, ensure the appliance is correctly grounded to prevent potential electrical hazards.

PROHIBITED ACTIONS

- Do not attempt to dismantle or repair any components unless explicitly directed by the manufacturer.
- Ensure the appliance is positioned in a manner that doesn't put pressure on the electrical cord or plug.
- Avoid hanging or placing excessive weight on the appliance doors to prevent personal injury.
- The appliance is not designed to store flammable or explosive substances. Keep such materials away.
- Tampering with or altering the electrical cord is strictly prohibited.

INSTALLATION & OPERATION

IMPORTANT!!! PLEASE READ BEFORE INSTALLATION

- If you've recently moved the unit, let it sit still for at least 24 hours before plugging it in.
- Before loading any items, ensure the unit cools down to the desired temperature.
- Ensure there's ample ventilation around the unit in its operating area.
- Before powering up the unit, check that all accessories, such as shelves, shelf clips, and casters, are installed.
- Thoroughly read this manual from start to finish.

CABINET LOCATION GUIDELINES

Set up the unit on a sturdy and level surface.

- The unit might make odd noises on an uneven surface.
- It might not work correctly if it's not level.
- Place the unit indoors in a well-ventilated spot.
- It'll work more efficiently with good airflow.
- For the best results, keep a clearance of about 3 inches at the back of the unit.
- Using it outdoors might reduce its efficiency and could damage it.
- Avoid areas with high humidity or a lot of dust.
- Too much moisture can cause the unit to rust and reduce its efficiency.
- Dust on the condenser coil can cause malfunctions. Brush or wipe down the condenser at least once a month.
- If the unit breaks down because of a dirty condenser, the warranty won't cover it.
- Don't place the unit near equipment that produces a lot of heat or moisture.
- High temperatures will make the compressor work harder, increasing your energy bills and wearing out the unit faster.
- The warranty will not cover malfunctions caused by high ambient temperatures.

ELECTRICAL

Ensure the compressor receives the correct voltage consistently. Voltage fluctuations can harm the refrigeration unit. Plug all units into a grounded electrical outlet that's appropriately sized and has the right overcurrent protection. Check the unit's nameplate for specific electrical requirements. Each unit should have its dedicated outlet. Avoid using extension cords.

TEMPERATURE CONTROLS

The units come preset to maintain average temperatures of 38°F for refrigerators and 0°F for freezers. If you need a different temperature, use the control knob inside the unit. Turn the knob clockwise to cool down and counter-clockwise to warm up.

CAUTION

Setting the temperature too cold might cause the evaporator coil to freeze, leading to a warmer interior temperature over time.

LOADING PRODUCT

Your unit's shelves are pre-installed. Before loading, ensure all shelf clips are securely in place. All shelves should be level before you stock them. To ensure proper airflow, maintain a 2 to 4-inch gap between products and the back wall. Blocking the evaporator fans can raise the internal temperature and may lead to compressor issues.

DEFROST SYSTEMS

Refrigerator coils operate below 32°F. When the compressor is off, the evaporator fan keeps

circulating air, preventing frost buildup. Any meltwater drains into the evaporator pan and evaporates. Freezer coils use electric defrosting. Built-in automatic defrost timers activate at set intervals and durations.

NOTE: Limit frequent door openings to maintain the internal temperature and prevent coil freezing.

LOADING FOOD PANS

Pizza and sandwich prep units need all pans in place, even if some are empty. For freshest results, fill pans with only what you'll use in a short time. When not in use, close the insulated lid.

MAINTENANCE AND CLEANING

CONDENSER COIL CARE

To ensure your unit runs efficiently, keep the condenser surface clear of dust, dirt, and lint.

Set a monthly reminder to clean the condenser coil and fins.

Use a specialized condenser coil cleaner, which you can find at kitchen equipment stores. When brushing the condenser fins, always go from top to bottom. Avoid brushing side to side.

If you notice any bent condenser fins, straighten them using a fin comb.

FAN BLADES AND MOTOR MAINTENANCE

If the fan blades appear dirty, gently clean them with a soft cloth. Should they need a more thorough wash, shield the fan motor to prevent any moisture-related damage.

INTERIOR CLEANING TIPS

For the cabinet's interior, mix warm water with a mild soap to create a cleaning solution.

Steer clear of steel wool, harsh soaps, abrasive cleaners, or bleach. These can harm the stainless steel finish.

Make it a habit to clean the door gaskets weekly. To do this, detach the gasket from the door frame, immerse it in soapy warm water for about 30 minutes, then dry with a soft cloth before reattaching.

After repositioning the gaskets, ensure they seal properly.

From time to time, take out the shelves and pilasters for cleaning. Use the same mild soap and warm water mixture. To remove pilasters, first take off the shelves and shelf brackets. Then, lift the pilaster up and out.

SAFETY FIRST

Always unplug the unit from the power source before cleaning any part of it.

TROUBLESHOOTING

SYMPTOM	POSSIBLE CAUSE	CORRECTIVE ACTION
Compressor not running.	Fuse blown or circuit breaker tripped.	Replace fuse or reset circuit breaker.
Power cord unplugged.	Plug in the power cord.	
Condensing unit runs for long periods.	Thermostat set too high.	Adjust thermostat to a cooler setting.
Cabinet in defrost cycle.	Wait for the defrost cycle to complete.	
Excessive warm product in cabinet.	Allow time for the product to cool.	
Door open too long or not sealed.	Close doors promptly and check for obstructions.	
Door gasket(s) not sealing.	Check gaskets, clean or replace if needed.	
Dirty condenser coil.	Clean the condenser coil.	
Evaporator coil iced over.	Unplug and let the coil defrost. Adjust thermostat if set too cold.	
Cabinet temperature too warm.	Thermostat set too warm.	
Door gasket(s) not sealing.	Ensure gaskets are in place and sealing.	
Cabinet is noisy.	Blocking airflow.	Re-arrange items for proper airflow. Ensure 4-inch clearance from evaporator.
Excessive warm product in cabinet.	Allow time for the product to cool.	
Fuse blown or circuit breaker tripped.	Replace fuse or reset circuit breaker.	
Dirty condenser coil.	Clean the condenser coil.	
Door open too long or not sealed.	Close doors promptly and check for obstructions.	
Evaporator coil iced over.	Refer to the corrective action above.	
Loose parts.	Identify and secure any loose components.	
Tubing vibration.	Ensure tubing isn't touching other components or tubing.	



WARRANTY

LIMITED WARRANTY

Koolmore Supply, Inc. extends a limited warranty to the original purchaser, guaranteeing that this Koolmore product is free from manufacturing defects in material or workmanship for one year from the date of purchase.

Should you discover any such defect within the warranty period, Koolmore Supply, Inc., reserves the right to repair or replace the product without charge, or to cover the cost of replacement parts and repair labor needed to correct defects present at the time of purchase or resulting from regular usage, when the appliance has been installed, operated, and maintained as per the instructions provided.

At its sole discretion, Koolmore Supply Inc. may decide to replace the product. In such an event, your replacement appliance will carry the warranty for the remaining term of the original unit's warranty period.

This warranty is valid exclusively to the original purchaser of the product and only applicable within the United States. The warranty commences from the date of original consumer purchase. Proof of the original purchase date will be required to obtain service under this warranty.

Under this limited warranty, your sole and exclusive remedy will be product repair, as outlined above. All services must be provided by a Koolmore-designated service company.

To claim warranty or request repair service:

Email support@koolmore.com. Please include your name, address, phone number, warranty repair request, and a copy of your proof of purchase receipt. Alternatively, visit koolmore.com and use the contact us page. A Koolmore customer service representative will promptly arrange service for your appliance.

We thank you for choosing Koolmore.

WARRANTY EXCLUSIONS

This limited warranty will not cover:

1. Failure of the product to perform during power failures or interruptions, or due to inadequate electrical service.
2. Damage incurred during transportation or handling.
3. Damage caused by accidents, vermin, lightning, winds, fire, floods, or acts of God.
4. Damage resulting from accidents, alterations, misuse, abuse, improper installation, repair, or maintenance. This includes using any external device that alters or converts the voltage or frequency of electricity.
5. Unauthorized product modifications, repairs by unauthorized centers, or use of non-approved replacement parts.
6. Abnormal cleaning and maintenance not aligned with the user's manual.
7. Use of incompatible accessories or components.
8. Any costs associated with repairs or replacements under these excluded circumstances shall be the responsibility of the consumer.

