



# SPEC SHEET

## KoolMore 71 in. Two Door Commercial Pizza Prep Refrigerator in Stainless-Steel

SKU: KM-RPPS-2DSS

### FEATURES

- **Refrigerated Storage:** Equipped with refrigerated storage beneath the prep area to keep ingredients fresh and at a safe temperature.
- **Durable Material:** Constructed from high-quality stainless steel, ensuring durability and ease of maintenance.
- **Auto/Cycle Defrost:** Features an auto/cycle defrost system that helps maintain optimal cooling and performance without manual defrosting.
- **Efficient Temperature Control:** Offers a precise temperature range from 33 to 40 Degrees F, suitable for various types of food storage.
- **Easy to Clean:** Stainless steel surfaces are easy to wipe down, promoting hygiene and cleanliness in food preparation areas.



# TECHNICAL SPECS

Specification	Detail
Product Dimensions	70.86 in (L) x 31.49 in (W) x 39.45 in (H)
Product Weight	431 lbs
Material	Stainless Steel
Color/Finish	Stainless Steel
Ambient Temperature Range	90 Degrees F
Amps	5.5
Certifications	ETL Listed
Cubic Feet	17
Defrost Type	Auto / Cycle
Depth (Excluding Handles)	31.49 in
Door Style	Solid Door
Height to Top of Door Hinge	33 in
Interior Depth	27.16 in
Interior Height	22.91 in
Interior Width	48.58 in
Number of Doors	2 Door
Number of Shelves	2
Plug Type	NEMA 5-15P
Refrigerant Type	R-290
Shelf Material Type	Wire
Temperature Range	33 - 40 Degrees F
Voltage	120

# Plan View

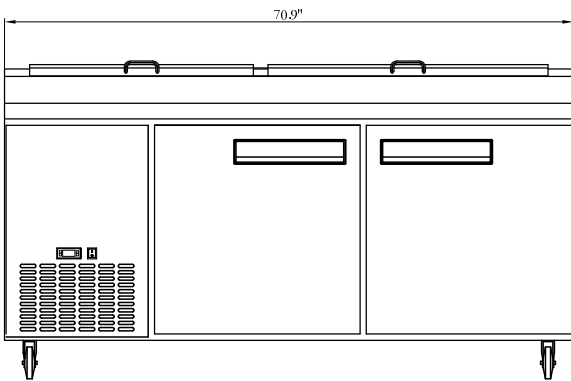

ELEVATION

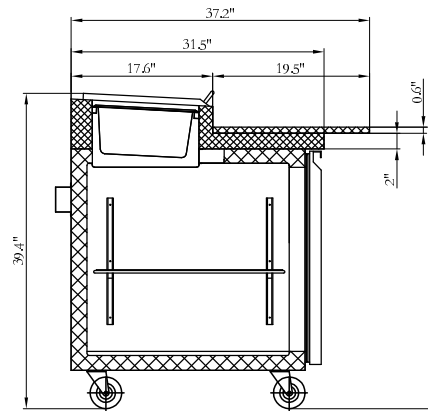

SECTION VIEW

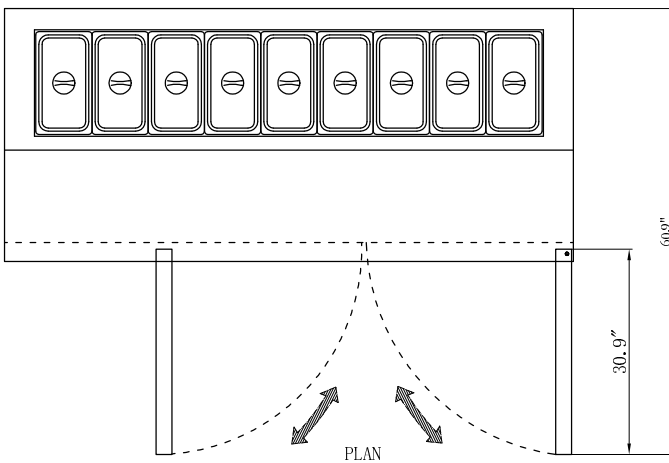

PLAN

## CERTIFICATIONS



Intertek



Intertek



706 Eastern Parkway STE 1G, Brooklyn NY 11213  
718-576-6342  
info@koolmore.com