



SPEC SHEET

KoolMore 57 in. 16-Gauge 2-Compartment Commercial Sink with 18 in. Right drainboard, Bowl Dimensions 18"x18"x14" in Stainless-Steel

Model:KM-SB181814-18R316

FEATURES

- NSF certified for sanitation and food safety.
- Seamless stainless steel construction for hygiene and easy cleaning.
- Corrosion-resistant finish maintains a pristine appearance.
- Eco-friendly materials and manufacturing processes.
- Large capacity design accommodates diverse kitchen tasks.
- Wall-mounted installation option for space-saving solutions.
- Ergonomic design promotes comfort and efficiency.



CLOSE UP IMAGES



TECHNICAL SPECS

Dimensions

Length	56.88
Width	24
Height	43.13
Weight (lbs)	70
DxWxH of Bowl 1	18"x18"x14"
DxWxH of Bowl 2	18"x18"x14"
Space Between Basins	1.2"
Height From Floor to Bottom of Basin	19.44
Height From Floor to Top of Basin	33.46
Legs Height	18.11
Left Drainboard Length	N/A
Right Drainboard Length	17.99
Backsplash Size	9.72

Features & Materials

	stainless steel
Exterior Material	silver gray
Color Finish	Yes
Drain Included	2
Number of Basins	2 degrees
Angle of Downward Incline in Basin	6 degrees
Angle of Downward Incline of Dashboard	
Legs Adjustable	Yes

Certifications

Certifications	NSF
----------------	-----

Plan View

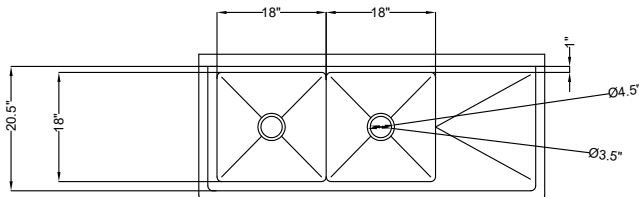
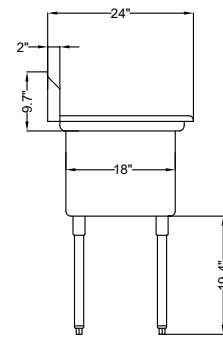
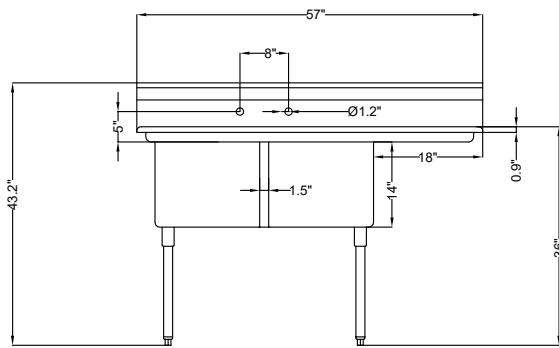

CERTIFICATIONS



706 Eastern Parkway STE 1G, Brooklyn NY 11213
718-576-6342
info@koolmore.com