



SPEC SHEET

KoolMore 57 in. 18-Gauge 2-Compartment Commercial Sink with Backsplash and 18 in. Right Drainboard, Bowl Dimensions 18"x18"x14" in Stainless-Steel

Model:KM-SB181814-18R3

FEATURES

- NSF certified for sanitation and food safety
- Seamless stainless steel construction for hygiene and easy cleaning
- Corrosion-resistant finish maintains pristine appearance
- Eco-friendly materials and manufacturing processes
- Large capacity design accommodates diverse kitchen tasks
- Wall-mounted installation option for space-saving solutions
- Ergonomic design promotes comfort and efficiency.



CLOSE UP IMAGES



TECHNICAL SPECS

Dimensions

Length	56.89
Width	23.94
Height	43.11
Weight (lbs)	57
DxWxH of Bowl 1	18"x18"x14"
DxWxH of Bowl 2	18"x18"x14"
Space Between Basins	1.2"
Height From Floor to Bottom of Basin	19.44
Height From Floor to Top of Basin	33.46
Legs Height	18.11
Left Drainboard Length	N/A
Right Drainboard Length	17.99
Backsplash Size	9.72

Features & Materials

Exterior Material	stainless steel
Color Finish	silver gray
Drain Included	Yes
Number of Basins	2
Angle of Downward Incline in Basin	2 degrees
Angle of Downward Incline of Dashboard	6 degrees
Legs Adjustable	Yes

Certifications

Certifications	NSF
----------------	-----

Plan View

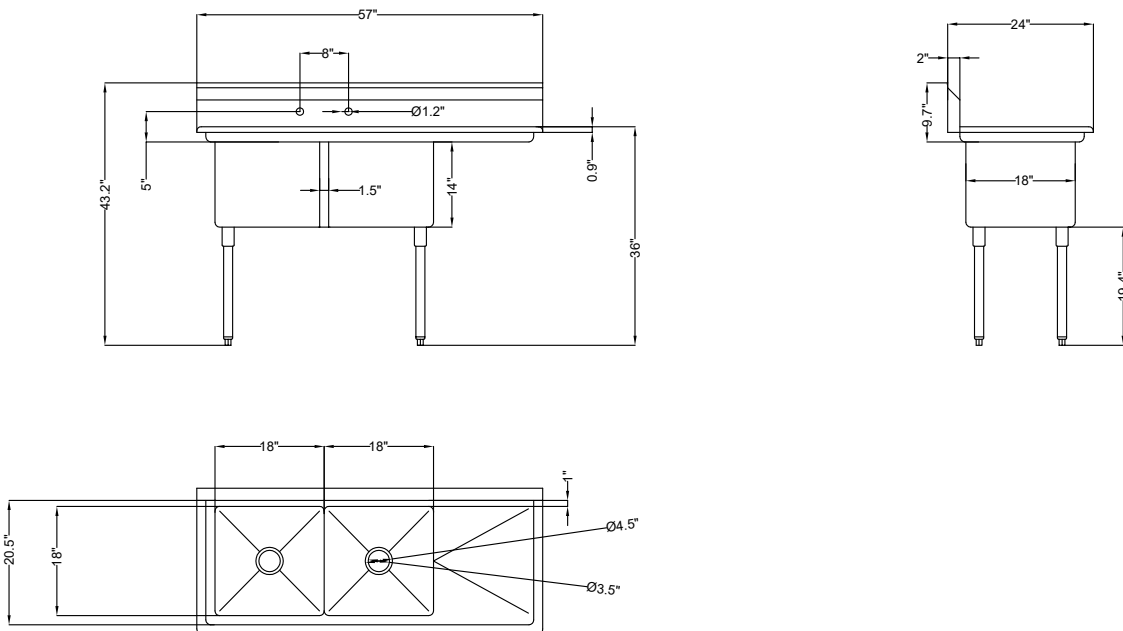

CERTIFICATIONS



706 Eastern Parkway STE 1G, Brooklyn NY 11213
718-576-6342
info@koolmore.com