



# SPEC SHEET

## 100 In. Three-Door Commercial Chest Freezer, 50 Cu. Ft. in White

Model: KM-SCF-50C

### FEATURES

- **Massive 50 Cu. Ft. Capacity for Bulk Storage:** Designed for high-volume storage, this extra-large chest freezer offers 43 cu. ft. net capacity, making it ideal for restaurants, supermarkets, and foodservice operations.
- **Triple Lid Design for Organized Access:** Features three top-opening lids that allow you to access specific sections without exposing the entire interior, helping maintain temperature and improve efficiency.
- **Wide Temperature Range (-11°F to 41°F):** Convertible functionality allows use as a freezer or refrigerator, giving flexibility to store frozen goods or chilled products as needed.
- **Durable Commercial-Grade Construction:** Built with a painted steel exterior and aluminum interior, designed to withstand heavy-duty commercial use while maintaining durability and easy cleaning.
- **Static Cooling with Consistent Performance:** Provides reliable, even cooling throughout the unit, ensuring stored products maintain proper temperatures over time.
- **Easy-to-Use Mechanical Temperature Controls:** Conveniently located controls at the bottom right allow quick and simple adjustments for precise temperature management.
- **Secure Storage with Built-In Safety Locks:** Each lid includes a lock to keep contents secure, making it ideal for shared or customer-facing environments.
- **High Mobility with 8 Heavy-Duty Casters:** Equipped with eight casters for easy movement and repositioning, even when fully loaded.



### CLOSE UP IMAGES

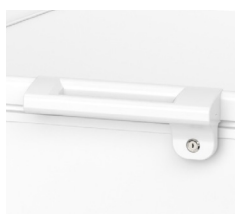
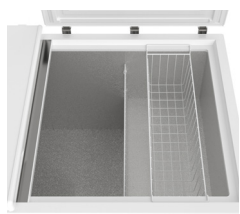

# Technical Specs

## Dimensions & Weight

Length	101.7"
Width	41.5"
Height	33.5"
Weight Lbs.	294 lbs.
Interior Depth	31.3"
Interior Width	95.5"
Interior Height	26.4"
Depth Including Handles	41.5"
Depth Excluding Handles	38.8"
Depth With Door Open 90 Degrees	70.5"
Minimum Side Air Clearance In.	4"
Minimum Back Air Clearance In.	5"

## Electric & Certifications

Hertz	60
Phase	1
Wattage	270
Voltage	115
Amps	3.8
Plug Type	NEMA 5-15P
Power Cord Included	Yes
Power Cord Length	70.1 in.
Certifications	ETL Listed for Safety and Sanitation

## Capacity

Gross Cubic Feet	49
Net Cubic Feet	43
Number of Freezer Baskets Bins	1
Individual Bin Capacity	33 lbs.

## Features & Materials

Temperature Range	-11-41°F
Ambient Temperature Range	95°F
Defrost Type	Manual
Cooling Unit Type	Static
Refrigerant Type	R290
Temperature Control Type	Mechanical
Low Temperature Alarm	No
Horsepower	0.75
Color	White
Color Finish	White
Interior Color	Silver
Door Handles Color	White
Door Style	Vertical Swing
Number of Doors	3
Interior Material	Aluminun
Exterior Material	Painted Steel
Interior Lights	No
Safety Lock	Yes
Convertible	Yes
Installation Type	Freestanding
Caster	8
Control Location	Exterior
Noise	52 dB
Compressor Location	Bottom
Handle Type	Standard
Indoor/Outdoor	Indoor

# Plan View

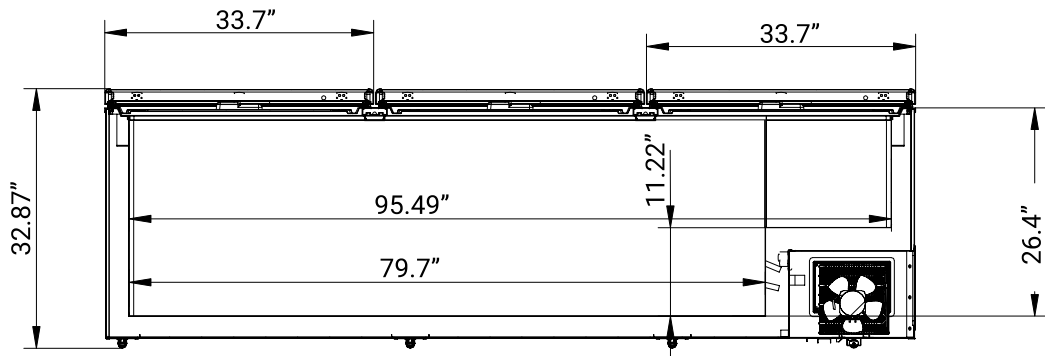

SECTION A—A

B

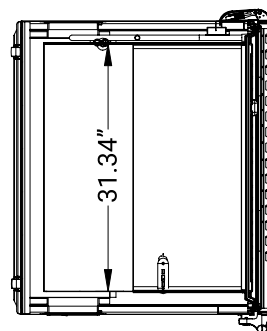
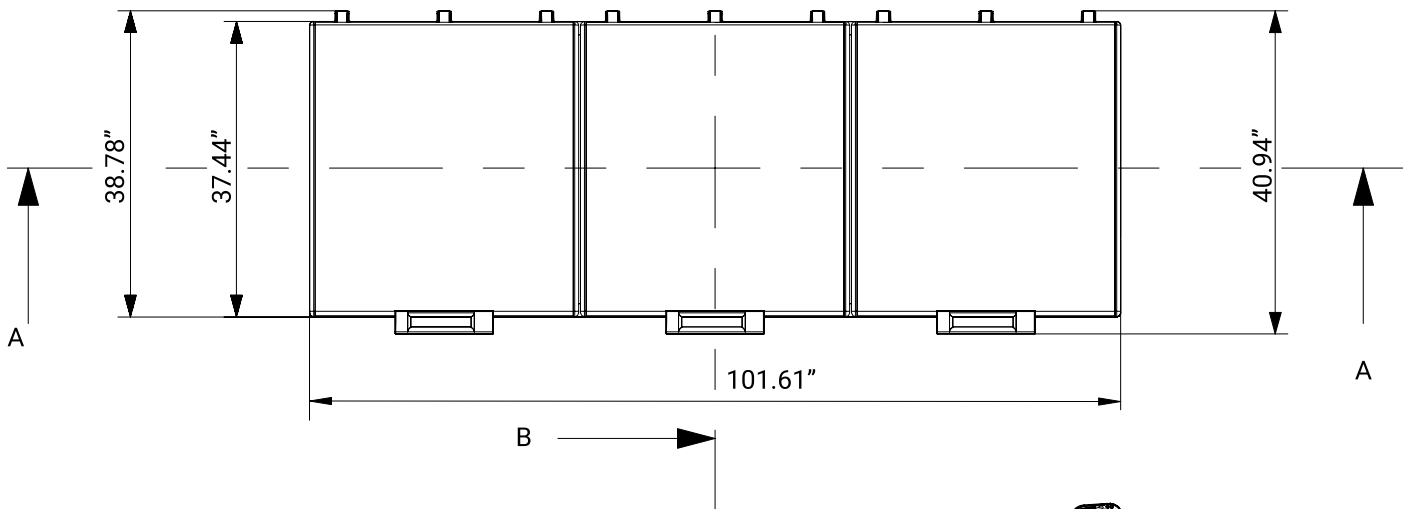

SECTION B—B

CERTIFICATIONS

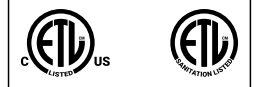

718-576-6342  
info@koolmore.com