



# SPEC SHEET

## KoolMore 48 in. Two-Door Commercial Undercounter Freezer

SKU: KM-UCF-2DSS

### FEATURES

- ETL Listed for Safety and Sanitation
- Fully insulated polyurethane insulation for energy efficiency
- Utilizes R290 refrigerant for eco-friendly operation
- Internal lighting for enhanced visibility



### CLOSE UP IMAGES



# TECHNICAL SPECS

## Dimensions

Depth	47.2
Width	29.5
Height	35.2
Interior Depth	19.8
Interior Width	42.6
Interior Height	23.5
Shelf Width	20.8
Shelf Depth	17.1
Depth Including Handles	29.5
Depth Excluding Handles	29.5
Depth Less Door	50.8
Depth With Door Open 90 Degrees	50.8
Power Cord Length	98.5

## Capacity

Weight	213.4
Gross Cubic Feet	11.9
Net Capacity Cu. Ft.	10.2
Individual Shelf Capacity	88 lbs.
Top Capacity	550

## Features & Material

Door Style	Swing
Number Of Doors	2
Number Of Shelves	2
Defrost Type	Automatic
Refrigerant Type	R290
Temperature Control Type	Digital
Ambient Temperature Range	100 F
Temperature Range	-8-0F
Casters	4
Light Type	NA
Shelf Material Type	Plastic Coated
Interior Material	SS 201
Exterior Material	SS 430

## Electric Data & Certifications

Amps	4.5
Phase	1
Plug Type	NEMA 5-15P
Voltage	115
Hertz	60
Wattage	300
Horsepower	0.544
Certifications	ETL Listed for Safety and Sanitation

# Plan View

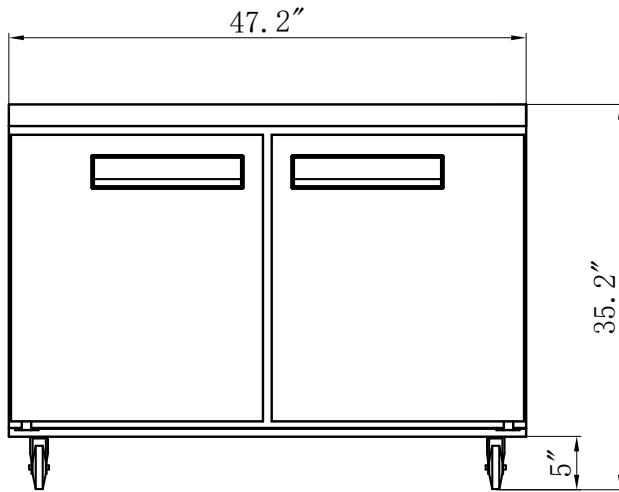

ELEVATION

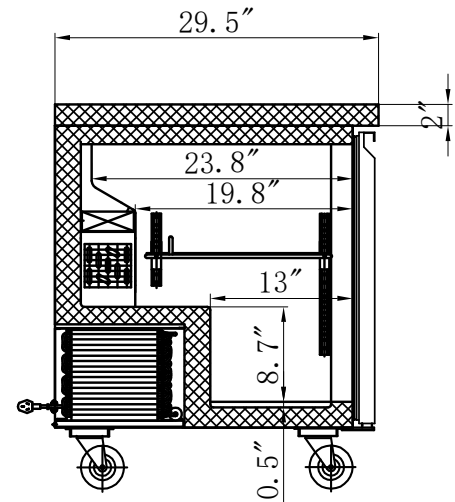

SECTION VIEW

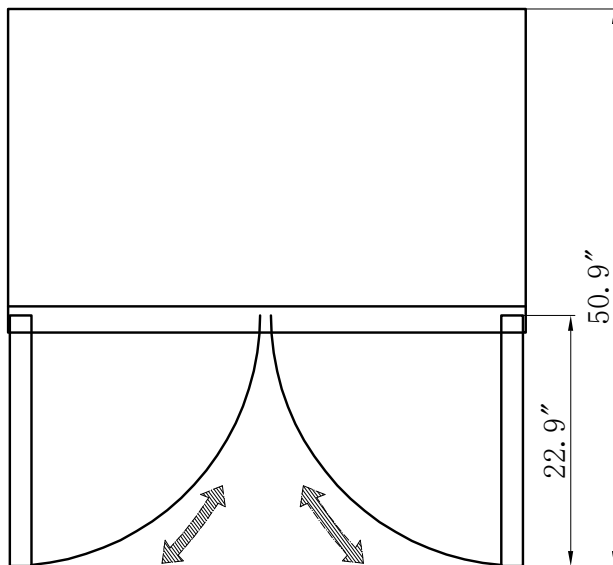

PLAN

## CERTIFICATIONS



Intertek



Intertek



706 Eastern Parkway STE 1G, Brooklyn NY 11213  
718-576-6342  
info@koolmore.com