



# SPEC SHEET

## KoolMore 27 in. One Door Commercial Undercounter Refrigerator 5 cu. ft. in Stainless-Steel

SKU: KM-UCR-1DSS

### FEATURES

- ETL Listed for Safety and Sanitation
- Fully insulated polyurethane insulation for energy efficiency
- Utilizes R290 refrigerant for eco-friendly operation
- Internal lighting for enhanced visibility
- Elegant and Easy to Clean
- Premium Stainless-Steel Construction
- Superior Cooling Performance



### CLOSE UP IMAGES

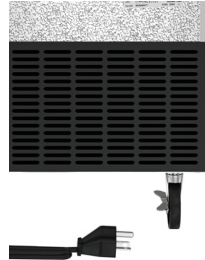

# TECHNICAL SPECS

## Dimensions

Depth	26.9
Width	29.5
Height	35.2
Interior Depth	19.8
Interior Width	22.3
Interior Height	23.5
Shelf Width	21.9
Shelf Depth	17.1
Depth Including Handles	29.52
Depth Excluding Handles	29.52
Depth Less Door	29.52
Depth With Door Open 90 Degrees	54 9/16"
Power Cord Length	98.5

## Capacity

Weight	158.4
Gross Cubic Feet	6.3
Net Capacity Cu. Ft.	5.4
Individual Shelf Capacity	88 lbs.
Top Capacity	550

## Features & Material

Door Style	Swing
Number Of Doors	1
Number Of Shelves	1
Defrost Type	Automatic
Refrigerant Type	R290
Temperature Control Type	Digital
Ambient Temperature Range	100 F
Temperature Range	33 - 40 F
Casters	4
Light Type	No Light
Shelf Material Type	Plastic Coated
Interior Material	Stainless Steel 201
Exterior Material	Stainless Steel 430

## Electric Data & Certifications

Amps	2.2
Phase	1
Plug Type	NEMA 5-15P
Voltage	115
Hertz	60
Wattage	210
Horsepower	0.3536
Certifications	ETL Listed for Safety and Sanitation

# Plan View

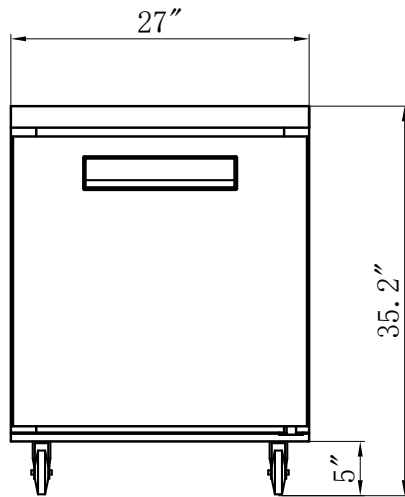

ELEVATION

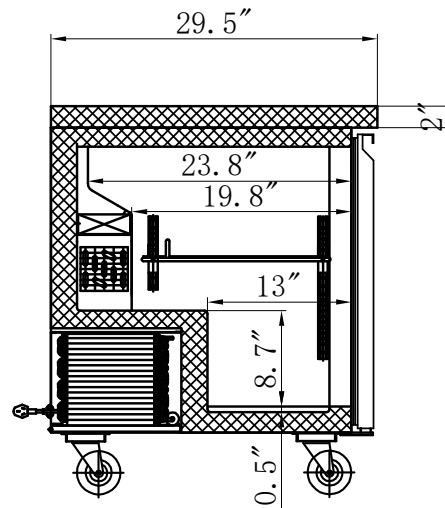

SECTION VIEW

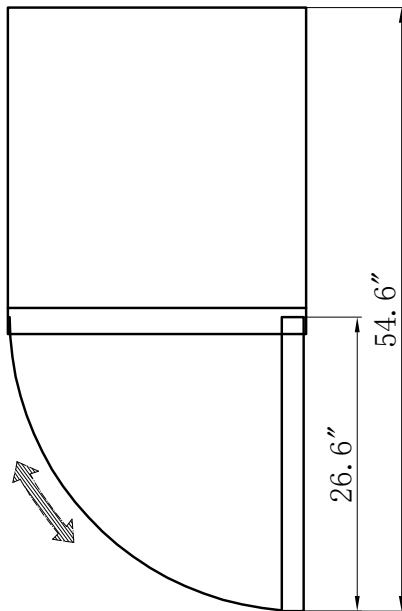

PLAN

## CERTIFICATIONS



Intertek



Intertek



706 Eastern Parkway STE 1G, Brooklyn NY 11213  
718-576-6342  
info@koolmore.com