



# SPEC SHEET

## 45 in. Two Glass Door Merchandiser Refrigerator, 35 Cu. Ft.

Model: MDR-2GD-35C

### FEATURES

- **Glass Display:** Large clear glass door showcases products for easy customer viewing and faster purchasing decisions.
- **Spacious Storage:** 35 Cu. Ft. with eight adjustable, corrosion-resistant shelves (71 lbs. capacity each) for versatile organization.
- **Convenient Mobility:** Four casters for easy movement, plus adjustable legs for stability on uneven floors.
- **Anti-Fog Glass:** Double-paned tempered glass reduces condensation to keep products visible at all times.
- **Durable Build:** Painted steel exterior and interior for a sleek, low-maintenance design suited for commercial use.
- **Bright LED Lighting:** 4.8W middle beam LED enhances product visibility with energy-efficient illumination.
- **Low-Maintenance Operation:** Automatic defrost and self-evaporation water tray reduce upkeep.
- **Precise Temperature Control:** Digital thermostat maintains 32°F to 50°F for optimal storage of beverages, dairy, and perishables.
- **Secure Storage:** Built-in safety lock protects inventory when not in use.
- **Certified & Warranted:** ETL certified with a 1-year parts and labor warranty for reliable performance and support.



### CLOSE UP IMAGES



# Technical Specs

## Dimensions & Weight

Length	44.49 in.
Width	28.35 in.
Height	79.65 in.
Weight	301 lbs.
Interior Depth	23.43 in.
Interior Width	40.66 in.
Interior Height	61.48 in.
Shelf Depth	21.73 in.
Shelf Width	19.88 in.
Depth Excluding Handles	27.16 in.
Depth Including Handles	28.35 in.
Depth Less Door	25.39 in.
Depth With Door Open 90 Degrees	48.9 in.
Height To Top Of Door Hinge	79.65 in.
Minimum Back Air Clearance	4 in.
Minimum Side Air Clearance	4 in.

## Electric & Certifications

Voltage	115
Wattage	380
Hertz	60
Amps	3.3
Phase	1
Plug Type	NEMA 5-15P
Power Cord Length	98 in.
Energy Consumption	1445.4 KWH/year
Electrical Installation Type	Plug-in
Certifications	ETL Listed for Safety and Sanitation

## Capacity

Gross Cubic Feet	31
Net Cubic Feet	26.8
Number of Shelves	8
Individual Shelf Capacity	71.65 lbs.

## Features & Materials

Temperature Range	32-50 F
Ambient Temperature Range	100.4
Cooling Unit Type	Automatic
Defrost Type	Automatic
Refrigerant Type	R-290
Installation Type	Freestanding
Horsepower	0.14
Number Of Doors	2
Door Style	Swing
Interior Lights	LED
Interior Lights Brightness	4.83 W
Interior Lights Color	White
Control Type	Digital
Color	Black
Color Finish	Black
Interior Color	White
Door Handle Color	Black
Door Material	Plastic
Door Handle	Pull Handle
Refrigerator Can Capacity	1124
Reversible Doors	No
Self Closing Door	Yes
Indoor / Outdoor	Indoor
Glass Type	Double Tempered
Noise	55 db
Shelves Adjustable	Yes
Shelf Material Type	Coated Metal
Interior Material	Galvanized Steel
Exterior Material	Precoated Steel
Casters	4
Safety Lock	Yes
Compressor Location	Bottom

# Plan View

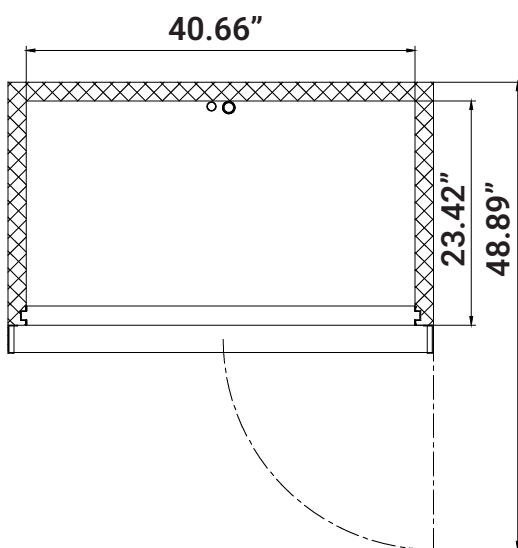
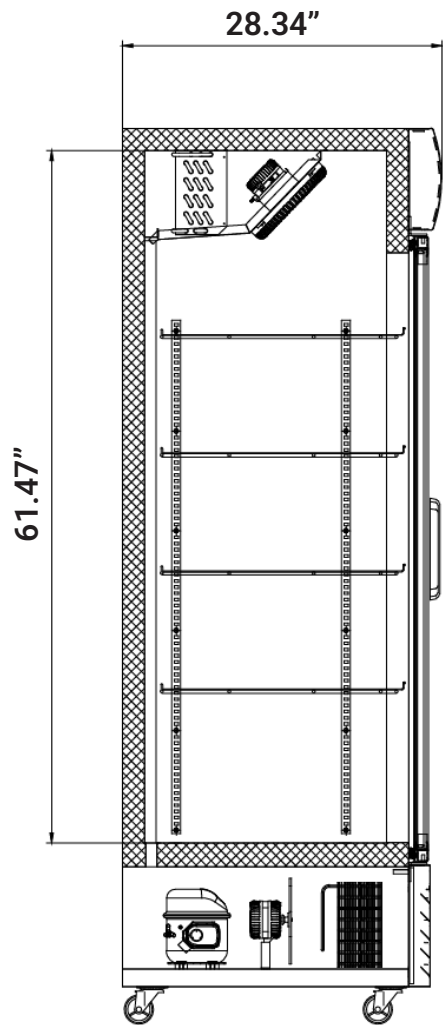
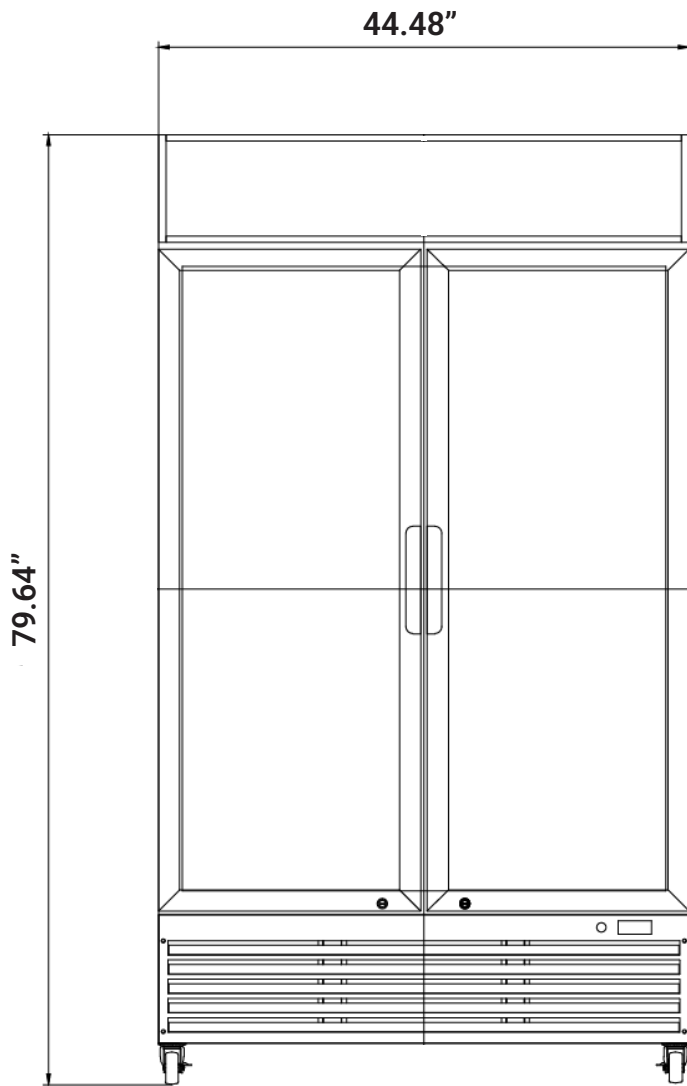

718-576-6342  
info@koolmore.com