



SPEC SHEET

54 in. Solid Half Door Commercial Reach-In Freezer, 47 cu. ft. in Stainless Steel

Model: RIF-2D-SSHD

FEATURES

- **Spacious Storage:** 47 Cu. Ft. with four adjustable, epoxy-coated steel shelves (88 lbs. capacity each) for versatile organization.
- **Efficient Auto Defrost:** Features an automatic defrost function that reduces the need for manual defrosting, ensuring minimal disruption.
- **External Digital Temperature Controls:** Easily monitor and adjust the temperature (-7-0 F) with the external digital display.
- **Bright Lighting:** A bright halogen light ensures your items are well-lit and visible, making it easy to locate.
- **Secure Key Lock:** Prevents unauthorized access and protects valuable inventory with a reliable key lock mechanism.
- **Portability:** Equipped with four casters, including two locking casters, for easy mobility and stability.
- **Self-closing:** Self-closing door (with a stay-open feature) maintains internal temperature and freshness.
- **Bottom-Mounted Compressor:** The bottom-mounted compressor and raised bottom shelf allow for easy loading, unloading, and maintenance.
- **Certified & Warranted:** ETL certified with a 1-year parts and labor warranty for reliable performance and support.



CLOSE UP IMAGES



Technical Specs

Dimensions & Weight

Length	54 in.
Width	32 in.
Height	82 in.
Weight	447 lbs.
Interior Depth	27.1 in.
Interior Width	49.4 in.
Interior Height	51.6 in.
Depth Excluding Handles	32.2 in.
Depth Including Handles	32.2 in.
Depth Less Door	29.4 in.
Depth With Door Open 90 Degrees	57.1 in.
Shelf Depth	23.2 in.
Shelf Width	23.6 in.
Minimum Back Air Clearance (in.)	Not Required
Minimum Side Air Clearance (in.)	1.2 in.

Electric & Certifications

Voltage	115
Wattage	780
Hertz	60
Amps	6.2
Phase	1
Plug Type	NEMA 5-15P
Power Cord Length	98.5 in.
Energy Consumption	3139 KWH/year
Power Cord Included	Yes
Electrical Installation Type	Plug-in
Certifications	ETL Listed for Safety and Sanitation

Capacity

Gross Cubic Feet	46.68
Net Cubic Feet	41.3
Number of Shelves	6
Individual Shelf Capacity	88 lbs.

Features & Materials

Temperature Range	-7-0 F
Ambient Temperature Range	100 F
Defrost Type	Automatic
Cooling Unit Type	Automatic
Refrigerant Type	R-290
Horsepower	1.29
Number of Doors	4
Door Handle	Recessed
Door Material	Stainless-Steel
Door Handle Color	Black
Self-Closing Door	Yes
Shelves Adjustable	Yes
Shelf Material Type	Epoxy Coated
Door Style	Swing
Interior Color	Stainless-Steel
Interior Lights	Fluorescent
Interior Lights Brightness	15 W
Temperature Control Type	Digital
Casters	4
Safety Lock	Yes
Legs Adjustable	No
Interior Material	Stainless-Steel 201
Exterior Material	Stainless-Steel 304
Color	Stainless Steel
Color Finish	Stainless-Steel
Compressor Location	Bottom

Plan View

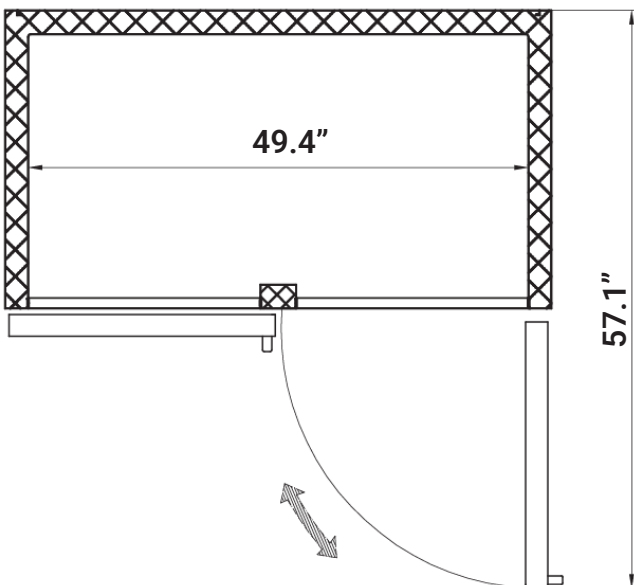
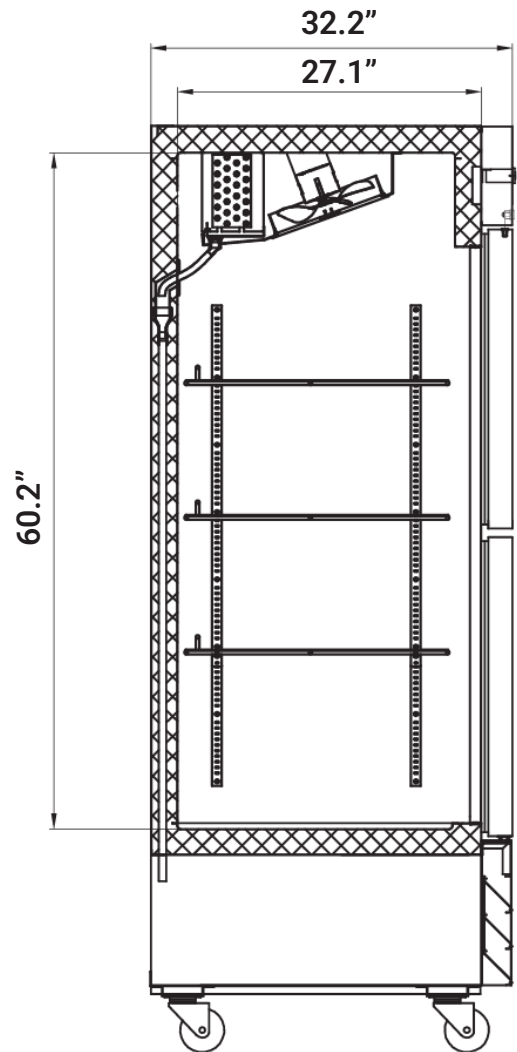
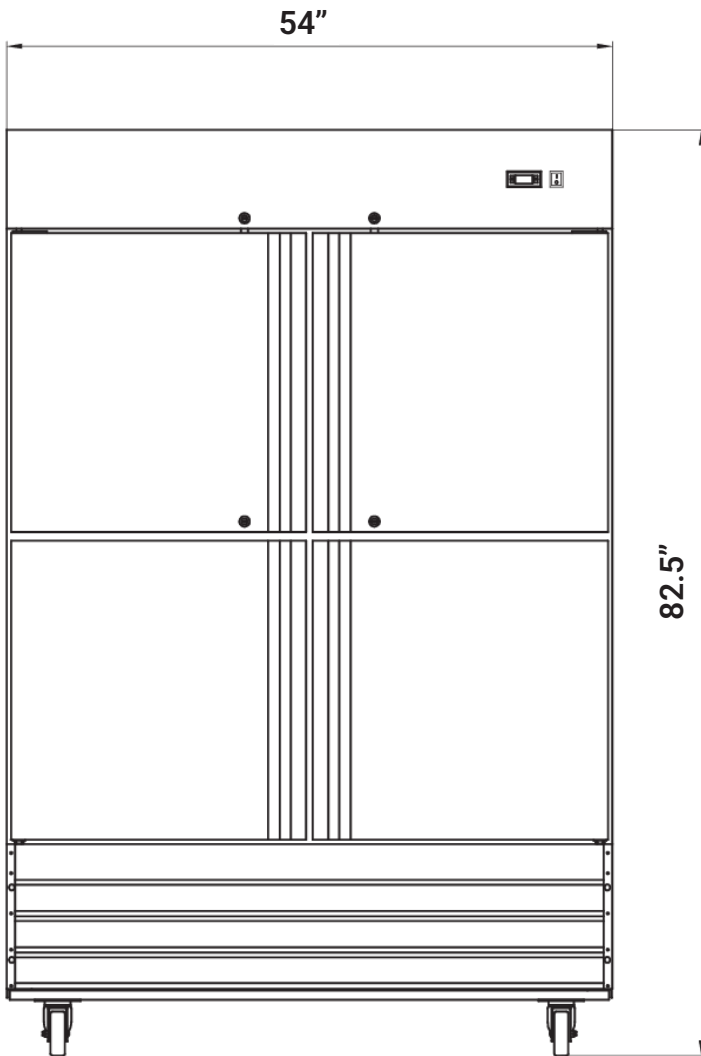

718-576-6342
info@koolmore.com