



SPEC SHEET

KoolMore 40 in. Three Pan Refrigerated Countertop Condiment Prep Station

Model: SCDC-3P-SG

FEATURES

- Digital temperature controls and display.
- Countertop design.
- Three 1/3 food Pans included.
- ETL Listed for Safety and Sanitation.
- Stainless Steel Body.
- Side Mounted compressor.
- Direct cooling system.
- Automatic defrost.



CLOSE UP IMAGES



TECHNICAL SPECS

Dimensions

Length	39.9
Width	15.5
Height	17.25
Interior Depth	12.24
Interior Width	25.59
Interior Height	6.5
Minimum Back Air Clearance In	5 in.
Minimum Side Air Clearance In	5 in.
Power Cord Length	112.2
Weightlbs	81.5

Capacity

Pan Capacity	3 1/3 GN Pans
Adjustable Pan Dividers	Yes
Included	3 1/3 GN Stainless-Steel Pans
Maximum Depth Of Pans	5.9

Features & Materials

Electrical Installation Type	Plug-in
Plug Type	NEMA 5-15P
Defrost Type	Automtic
Refrigerant Type	R-600a
Compressor Brand	Cubigel
Compressor Location	Right Side
Cooling Unit Type	Static
Temperature Range	35 - 46 F
Ambient Temperature Range	90 F
Exterior Material	Stainless-Steel 201
Interior Material	Stainless-Steel 201
Color Finish	Stainless-Steel

Electric & Certifications

Voltage	115
Wattage	110
Amps	1.6
Hertz	60
Phase	1
Horsepower	0.1
Certifications	ETL Listed for Safety and Sanitation
Ada Compliant	No
Energystar Compliant	Yes

Plan View

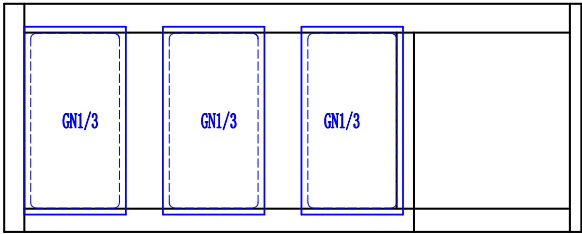
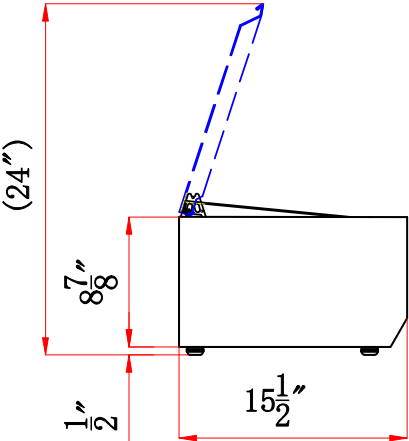
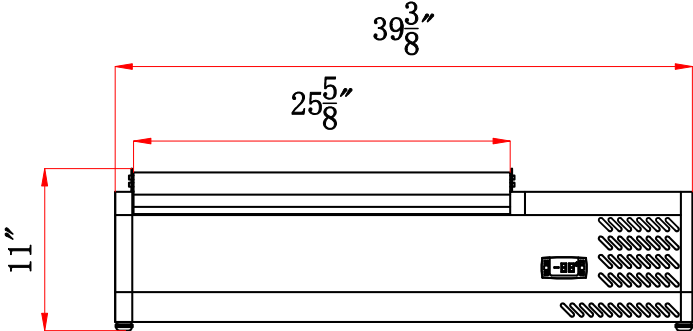

CERTIFICATIONS



Intertek Intertek



706 Eastern Parkway STE 1G, Brooklyn NY 11213
718-576-6342
info@koolmore.com