

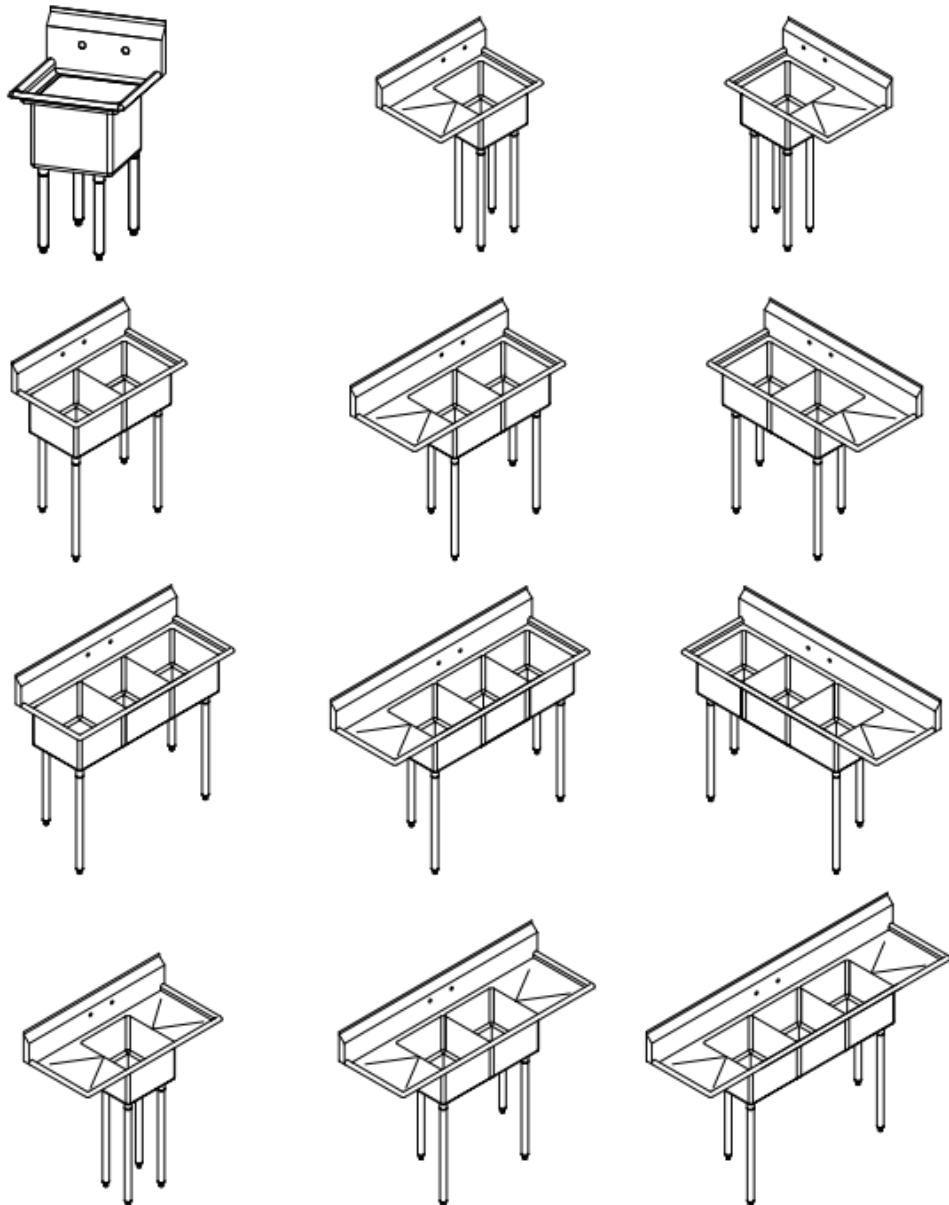

# INSTALLATION MANUAL

# COMPARTMENT SINK

## Commercial Stainless Steel Compartment Sink



**Caution: Before use, verify that the sink is securely mounted and fully supported.**

For any service related issues, please contact us:

☎ 718-576-6342    ✉ [support@koolmore.com](mailto:support@koolmore.com)

## Stay informed with the latest information for your KoolMore Appliance.

Scan the QR code below to access the most recent user manual on our website, which is constantly being updated and improved.

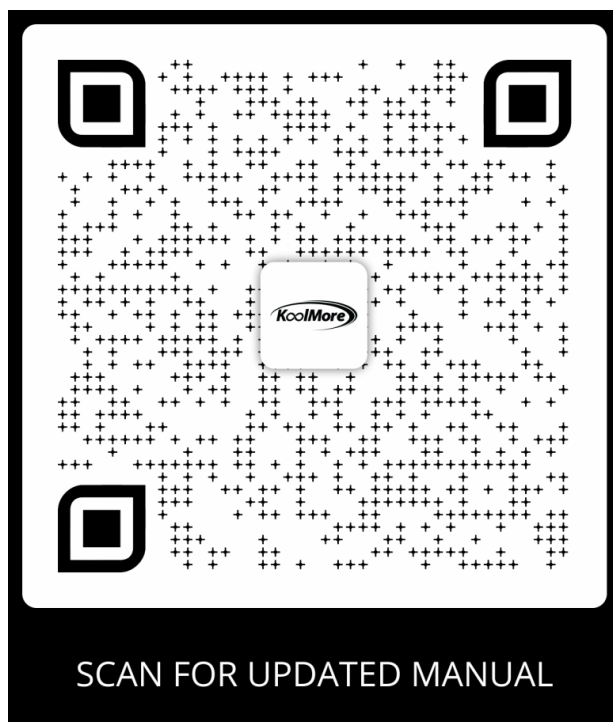

**If you need any assistance or have questions, our customer support team is here to help.**

**Phone- 718-576-6342 Email- [support@koolmore.com](mailto:support@koolmore.com)**

Please write down the model number and serial number below for future reference. Both numbers are located on the rating label on the back of your unit or inside of the unit and are needed to obtain warranty service. You may also want to staple your receipt to this manual as it is your proof of purchase and may also be needed for service under warranty.

Model Number: \_\_\_\_\_

Serial Number: \_\_\_\_\_

Date of Purchase: \_\_\_\_\_



To better serve you, please do the following before contacting customer service:

If you received a damaged product, immediately contact the retailer or dealer that sold you the product.

Read and follow this Installation Manual carefully to help you install, use, and maintain your unit.

Refer to the Troubleshooting section of this manual as it will help you diagnose and solve many common issues.

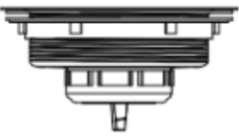
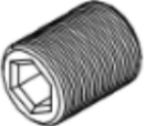
### Accessories

| Part Image  | Part Name       | Quantity               |
|---|-----------------|------------------------|
|  | Leg             | 4                      |
|  | Drain Basket    | Same as tub quantities |
|  | M8 x10 Screw    | 9                      |
|  | S4 Allen Wrench | 1                      |

1. Strainer

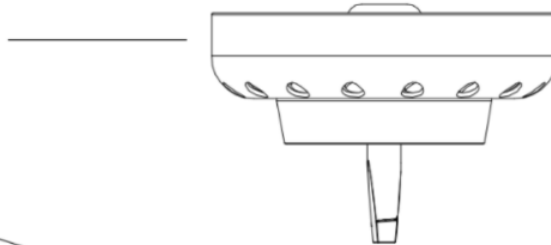

2. Strainer body

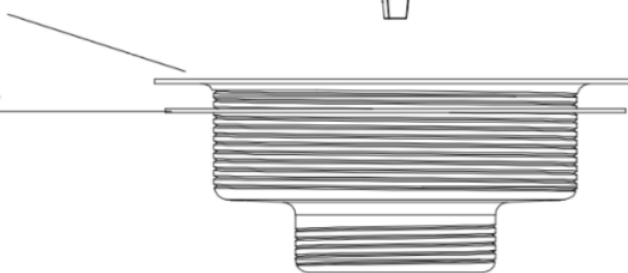

3. Rubber washer

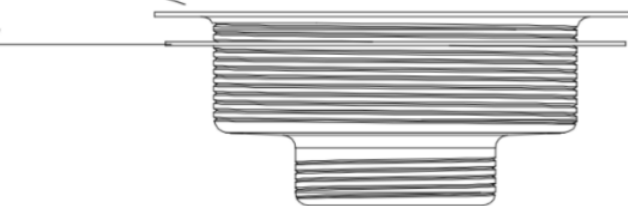

4. Paper gasket



5. Lock nut



6. Pipe joint

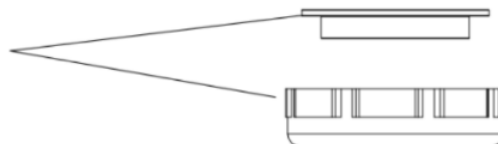

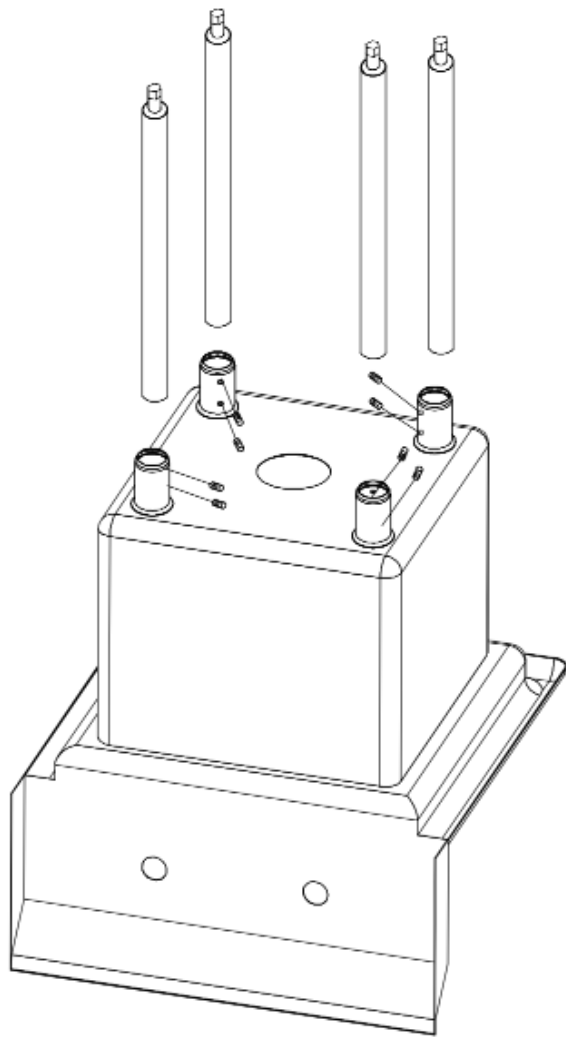

Strainer and  
Strainer body

Rubber washer

Paper gasket

Lock nut

Pipe joint

### Compartment Sink Assembly Instructions

1. Place the compartment sink upside down on the floor. Position the carton top underneath to provide padding and prevent scratches.
2. Insert the four legs into the leg sockets, then partially tighten the Allen screws to hold them in place.
3. Carefully stand the compartment sink upright.
4. Place the rubber washer beneath the strainer body, then insert the assembly into the sink's drain hole.
5. From underneath the sink bowl, attach the paper gasket and lock nut to the strainer body in sequence, then tighten securely.
6. After purchasing a suitable drain pipe, connect it to the strainer body beneath the sink bowl using a pipe joint.

**Note:** This sink is compatible with an 8-inch center wall-mount commercial faucet with a goose-neck or swing spout. The faucet is not included and must be purchased separately.



# WARRANTY

## LIMITED WARRANTY

---

KoolMore Supply Inc. extends a limited warranty to the original purchaser, guaranteeing that this KoolMore product is free from manufacturing defects in material or workmanship for one year from the date of purchase.

Should you discover any such defect within the warranty period, KoolMore Supply Inc. reserves the right to repair or replace the product without charge, or to cover the cost of replacement parts and repair labor needed to correct defects present at the time of purchase or resulting from regular usage, when the appliance has been installed, operated, and maintained as per the instructions provided.

At its sole discretion, KoolMore Supply Inc. may decide to replace the product. In such an event, your replacement appliance will carry the warranty for the remaining term of the original unit's warranty period.

This warranty is valid exclusively to the original purchaser of the product and only applicable within the United States. The warranty commences from the date of original consumer purchase. Proof of the original purchase date will be required to obtain service under this warranty.

Under this limited warranty, your sole and exclusive remedy will be product repair, as outlined above. All services must be provided by a KoolMore designated service company.

To claim warranty or request repair service:

Email [support@koolmore.com](mailto:support@koolmore.com). Please include your name, address, phone number, warranty repair request, and a copy of your proof of purchase receipt. Alternatively, visit [koolmore.com](http://koolmore.com) and use the Contact Us page. A KoolMore customer service representative will promptly arrange service for your appliance.

We thank you for choosing KoolMore.

## WARRANTY EXCLUSIONS

---

This limited warranty will not cover:

1. Damage incurred during transportation or handling.
2. Damage caused by accidents, vermin, lightning, winds, fire, floods, or acts of God.
3. Damage resulting from accidents, alterations, misuse, abuse, improper installation, repair, or maintenance.
4. Unauthorized product modifications, repairs by unauthorized centers, or use of non-approved replacement parts.
5. Abnormal cleaning and maintenance not aligned with the user's manual.
6. Use of incompatible accessories or components.
7. Any costs associated with repairs or replacements under these excluded circumstances shall be the responsibility of the consumer.

