



SPEC SHEET

KoolMore 72 in. 18-Gauge 2-Compartment Commercial Sink with Backsplash and Dual 18 in. Drainboards, Bowl Dimensions 18"x18"x14" in Stainless-Steel

Model:KM-SB181814-18B3

FEATURES

- NSF certified for sanitation and food safety
- Seamless stainless steel construction for hygiene and easy cleaning
- Corrosion-resistant finish maintains pristine appearance
- Eco-friendly materials and manufacturing processes
- Large capacity design accommodates diverse kitchen tasks
- Wall-mounted installation option for space-saving solutions
- Ergonomic design promotes comfort and efficiency.

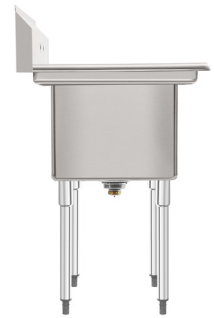

CLOSE UP IMAGES



TECHNICAL SPECS

Dimensions

Length	72
Width	23.88
Height	43.38
Weight (lbs)	63
DxWxH of Bowl 1	18"x18"x14"
DxWxH of Bowl 2	18"x18"x14"
Space Between Basins	1.2"
Height From Floor to Bottom of Basin	19.44
Height From Floor to Top of Basin	33.46
Legs Height	18.11
Left Drainboard Length	17.9
Right Drainboard Length	17.9
Backsplash Size	9.7

Features & Materials

Exterior Material	stainless steel
Color Finish	silver gray
Drain Included	Yes
Number of Basins	2
Angle of Downward Incline in Basin	2 degrees
Angle of Downward Incline of Dashboard	6 degrees
Legs Adjustable	Yes

Certifications

Certifications	NSF
----------------	-----

Plan View

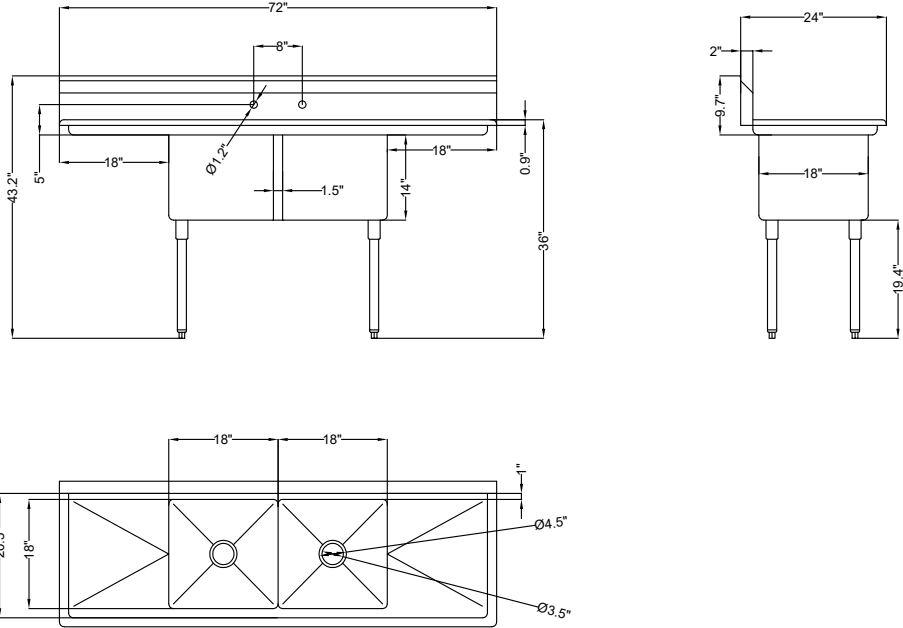

706 Eastern Parkway STE 1G, Brooklyn NY 11213
718-576-6342
info@koolmore.com