



SPEC SHEET

KoolMore 60 Inch Stainless Steel Wall Cabinet with Hinged Doors

Model: KM-WMC-1560-S

FEATURES

- **Secure Storage with Locking Doors:** Protects valuables with peace of mind in busy settings.
- **Durable Stainless-Steel Construction:** 304 stainless steel, 20-gauge, resistant to corrosion and heavy use.
- **Slanted Roof Design:** Prevents dust accumulation and simplifies cleaning for hygiene.
- **Ample Storage with High Load Capacity:** Two shelves each support up to 264.5 lbs for secure storage.
- **Space-Efficient Wall Mounting:** Comes with brackets for easy, secure installation in busy areas.
- **Smooth Hinged Doors:** Ensures easy access with reliable operation for quick and secure use.
- **Ventilation Slits:** Promotes air circulation to prevent moisture, keeping contents fresh.
- **Easy to Clean:** Stainless steel surfaces allow for quick sanitization, meeting health standards.
- **Robust Mounting Brackets:** Sturdy brackets ensure the cabinet stays mounted securely when loaded.
- **NSF Certified and 1 Year Manufacturer's Warranty:** Meets NSF safety standards with a 1-year warranty on parts and labor.



CLOSE UP IMAGES



Plan View

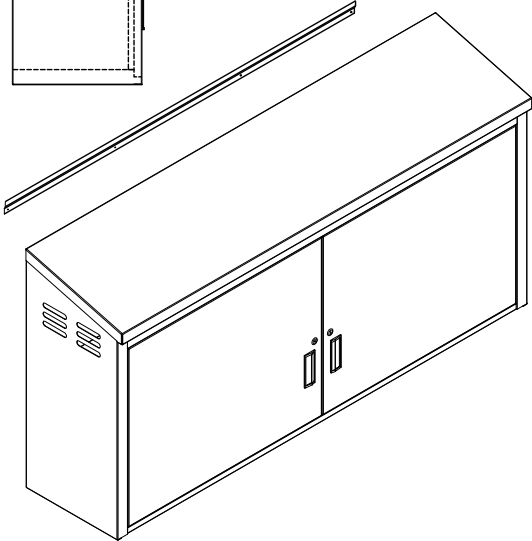
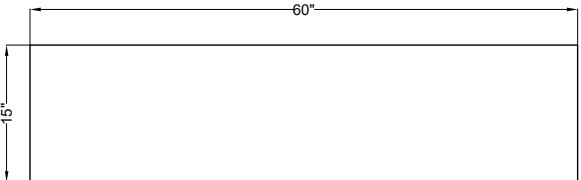
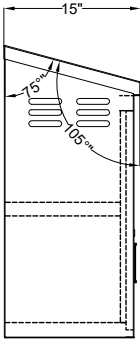
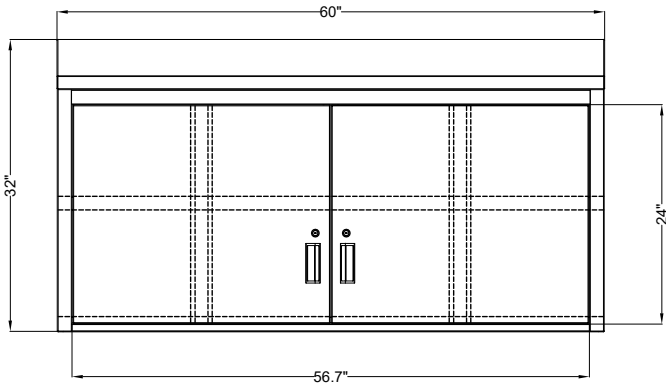

CERTIFICATIONS



706 Eastern Parkway STE 1G, Brooklyn NY 11213
718-576-6342
info@koolmore.com